

# MONTANA PLANS EXCHANGE

November 9th, 2015 VOL 21 ISSUE 45

Serving Montana  
Since 1964



[www.MontanaPlansExchange.com](http://www.MontanaPlansExchange.com)

◇ **KALISPELL**  
◇ **HELENA**  
◇ **MISSOULA**

**KALISPELL COPY CENTER** 755-5888 2303 HWY 2 EAST  
**HELENA COPY CENTER** 457-2679 1530 CEDAR ST C  
**MISSOULA COPY CENTER** 549-2679 2304 MCDONALD

**WWW.MTCOPYCENTERS.COM**

**YOUR WEEKLY SOURCE  
FOR DECISION MAKERS**

Montana Plans Exchange is published weekly  
for \$125.00 Quarterly by Charlie Hansen at:  
2303 Hwy 2 East Kalispell, Montana 59901  
USPS 001-118

Periodicals Postage Paid at Kalispell, MT 59901  
Postmaster: Send address corrections to:  
Montana Plans Exchange  
2303 Hwy 2 East Kalispell, Montana 59901

MONTANAJACKS.COM 406-755-2410



YOUR LOCAL  
DEALER &  
SERVICE CENTER

ATV & UTV  
SNOW PLOWS  
IN STOCK!

**WINCHES • HOISTS**



ATV • UTV  
TRUCK  
CONSTRUCTION  
INDUSTRIAL



220 Lost Creek Drive Kalispell, MT

COR-TEN® Rusting Steel • Copper

3' Tuf-Rib 28 ga. • 7/8" Corrugated

Custom Trim • Standing Seam

Metal Soffit • 24-48 Hour Delivery



110 Jensen Road Columbia Falls Montana

406-892-7525 • 877-897-7525 • Fax 892-7526

[www.glaciersteel.com](http://www.glaciersteel.com)

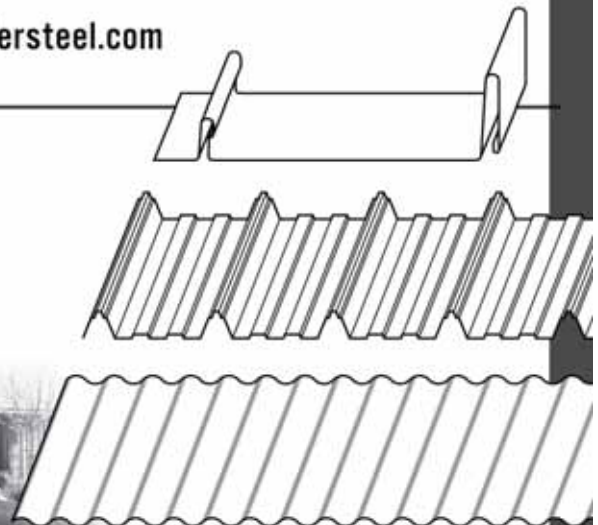

# MEMBERSHIP RATES & OPTIONS

1 QUARTER YEAR - \$125.00 OR 1 YEAR - \$329.00

If you would prefer **NOT** to receive our weekly mailing, you can download it from our site that you would still have full access to, for the reduced cost of:

1 QUARTER YEAR - \$105.00 OR 1 YEAR - \$295.00

***PUBLICATIONS ARE MAILED WEEKLY***

**PLEASE CHECK OUR ON LINE PLANS EXCHANGE SERVICE  
TO REVIEW THE PLANS ON FILE.**

***THIS WILL KEEP YOU UP TO DATE ON PLANS THAT MAY NOT HAVE BEEN  
RECEIVED IN TIME FOR PUBLICATION!***

**montanaplansexchange.com**

## **ADDENDA OR CHANGES**

Members are solely responsible for keeping up on all addenda or changes made by the Architects, Engineers, or Designers.

### FINE PRINT

There is no warranty, expressed or implied, that the information contained herein is accurate or timely.

We will always do our best to assure that the information is current however, for bidding purposes, YOU must verify the status of each project directly with the project architect or awarding agency to be sure you have all the necessary information. Not all projects, Pre bid conferences, bidders and/or addenda for the area are necessarily listed. As a subscriber and by using our service, you agree to these terms and conditions and waive and release all claims against Montana Plans Exchange of or related to your use of the information.

Montana Plans Exchange membership is restricted to a single business and their employees only. Sharing access to the web site with non-members is prohibited and will result in membership termination.

**Members can NOT transfer membership to subs & suppliers**

# ADVERTISING RATES

BUSINESS CARD RATES:	3 MONTHS	\$35.00
	6 MONTHS	\$55.00
	12 MONTHS	\$95.00
QUARTER PAGE RATES:	3 MONTHS	\$50.00
	6 MONTHS	\$70.00
	12 MONTHS	\$120.00
HALF-PAGE RATES:	3 MONTHS	\$75.00
	6 MONTHS	\$115.00
	12 MONTHS	\$210.00
FULL-PAGE RATES:	3 MONTHS	\$140.00
	6 MONTHS	\$210.00
	12 MONTHS	\$385.00

406-755-5888  
ads@kalcop.com

## **XEROX COPIES**

The Builders Exchange has wide format laser blackline printing capability (up to 36" wide)

This service is available for the following fees

**18 x 24 = 1.05**

**24 x 36 = 1.35**

**30 x 42 = 1.95**

**36 x 48 = 2.50**

**Large Format NOW  
available in COLOR!**













## **Small Format Printing**

also available in  
Black & White  
& **COLOR**

# ATTENTION ALL MEMBERS

You must click the ***Save project*** icon button. To continue to receive Emails notifications. Including addendums, memos, update, etc. This is to avoid unnecessary & un-wanted emails on project you are not interested in.



Take Off Tools	
<b>On-Screen Takeoff</b>	
<b>Quick Eye Estimator</b>	
Documents	
 <b>View Project Docs (Java)</b>	
 <b>File Downloader</b>	
 <b>Order Prints</b>	
 <b>HP Instant Printing</b>	
Project Actions	
 <b>View Activity</b>	
 <b>Email Project Info</b>	
 <b>Add Me To Bidders List</b>	
 <b>Save Project</b>	
 <b>Search Spec Books</b>	
 <b>Report Problem</b>	
<b>MTPE13-00676</b>	

# LIST OF PROJECTS

November 9, 2015

## PLANS AVAILABLE

\* Indicates Date/Time Change      \*\*\* Indicates Local Project

	<b>BID DATE</b>	<b>PROJECT NAME</b>	<b>LOCATION</b>	<b>BIN</b>	<b>ADD</b>
	11/9/2015	RFP: Land Reclamation, Rehabilitation, and Re-vegetation Services	Fort Harrison		1
<i>NEW</i>	11/9/2015	Pete Lien Lime Plan Water Well - Laramie	Laramie, WY		1
	11/9/2015	Crash Block Repair	South of Melrose, MT		
	11/9/2015	Black Hills National Forest Supervisors Warehouse and Trailer	Black Hills National Forest, SD		1
	11/10/2015	Construct Missoula College - Bid Package #3 – Culinary Arts Equipment	Missoula		
	11/10/2015	Rapid Transit Bus Storage Facility Expansion	Rapid City		2
	11/10/2015	OPI- MT Drive Driver Training Facility	Lewistown, MT		
	11/10/2015	Sheridan Area Water Supply Booster Station SCADA System Project	Sheridan, WY		1
	11/10/2015	Town of Belt Water Meter Installation 2015	Belt, MT		1
	11/10/2015	Roundup Elementary School - Furniture Installation	Roundup, MT		1
<i>NEW</i>	11/12/2015	Fountain Springs Community Church – East Campus Renovations	Rapid City, SD		
<i>NEW</i>	11/12/2015	Construction of Community Sewer Improvements on the Yankton Sioux Reservation	Wagner, SD		1
	11/12/2015	Neighbor Works 1st Avenue Estates	Great Falls, MT		3
	11/12/2015	University of Montana Liberal Arts Phase II Remodel Project No. UM 15-63	Missoula, MT		
	11/12/2015	HLRWSD Hayden Lake Country Club Lift Station	Hayden, ID		5
	11/12/2015	Hot Springs County Memorial Hospital MRI Remodel - Thermopolis	Thermopolis, WY		1
<i>NEW</i>	11/12/2015	Grandview Elementary School Shingle Roof Replacement	Rapid City, SD		
	11/12/2015	South Wind's Water System Replacement	Great Falls		1
<i>NEW</i>	11/13/2015	Billings Comfort Suites	Billings, MT		
	11/13/2015	WYDOT Highway Projects	Various, WY		9
<i>NEW</i>	11/16/2015	Demolish and Remove Old Water Treatment Plant - Huron	Huron, SD		
	11/17/2015	Minot AFB Design-Drainage, Repaving, Improvement Re-Bid	Minot, ND	Online	6
<i>NEW</i>	11/17/2015	Cody Meetinghouse Mural and Exhibit Improvements	Cody		
	11/17/2015	MRA URD III S. Reserve Ped Bridge	Missoula, MT		
	11/17/2015	Pedestrian Crosswalk System-Basin	Basin, WY		

	11/17/2015	Office & Maintenance Shop Addition and Remodel - SD DOT - Armour SD	Armour, SD	
	11/17/2015	Riverton Central Wyoming College Student Success Center and Campus Improvements	Riverton, WY	
NEW	11/17/2015	RFQ- North Seventh Urban Renewal District Engineering Services, City of Bozeman	Bozeman, MT	
NEW	11/18/2015	Helena High School Gym Re-Roof	Helena, MT	
NEW	11/19/2015	Faith Home - Heating System Replacement, Wolf Point	Wolf Point, MT	1
	11/19/2015	BENEFIS PHARMACY & RESPIRATORY THERAPY REMODEL	Great Falls	
NEW	11/19/2015	Dakota/Athletic/HPER Dome Renovation & Office Shell Space	Vermillion, SD	
NEW	11/19/2015	Viscom Photo Classroom Renovation MSU Bozeman	Bozeman, MT	
	11/19/2015	Glendo State Park-Sandy Beach Campsite Electrical Project	Platte Country, WY	
NEW	11/19/2015	DENNISON THEATRE LIGHTING UPGRADE, UNIVERSITY OF MONTANA, MISSOULA	Missoula, MT	
	11/19/2015	Black Pine Mine Reclamation Construction - Phillipsburg	Phillipsburg, MT	3
	11/19/2015	Landscaping Sheridan VAMC, Wyoming	Sheridan	
	11/19/2015	Kemmerer Recreation Center Re-Roof	Kemmerer, WY	
	11/19/2015	MRI Building -Cheyenne, WY	Cheyenne, WY	5
NEW	11/19/2015	North Middle School Roof Replacement	Rapid City, SD	
	11/19/2015	Lincoln Road Request for Proposal - Engineering Services	Helena	
NEW	11/19/2015	Elevator Maintenance and Repair - BHHCS	Fort, SD	
	11/19/2015	MDOT - 7TH AVE ADA RAMPS - LEWISTOWN	Lewistown, MT	
	11/19/2015	MDOT - RESERVATION CREEK - E And W	Rosebud County, MT	
	11/19/2015	MDOT - SF 129 - ITS/VMS ROGERS PASS	Rogers Pass, MT	
	11/20/2015	Generator Excitation Systems for Big Bend Dam, SD	Big Bend, SD	3
NEW	11/20/2015	2016 Holiday Booster Station Electrical Upgrades and Improvements Project - Spearfish, SD	Spearfish, SD	
	11/23/2015	Wastewater Treatment Improvements WWTP Upgrades Deer Lodge	Deer Lodge, MT	
	11/24/2015	Hill County Courthouse Exterior Envelope Restoration	Havre, MT	
NEW	11/24/2015	Construction Manager at Risk for Additions & Renovations to Waste Transfer Station - Cheyenne	Cheyenne, WY	1
NEW	11/24/2015	RFQ - Architectural, Engineering, Planning and Consultant Services for Airport Grant Projects	Rapid City, SD	
	11/24/2015	Cascade County Copper Roof Replacement	Great Falls, MT	
NEW	11/24/2015	Western Montana Clinic- Now Care Relocation - Southgate Mall - Missoula	Missoula, MT	1
	11/25/2015	Cooling Equipment Replacement Ft. Harrison, Montana	Fort Harrison, MT	1
NEW	11/25/2015	Repair MAF Windows, Insulation, Siding - Malmstrom AFB - Great Falls	Malmstrom AFB, MT	

<i>NEW</i>	11/30/2015	RFQ Historic Window Restoration and Replication	Cheyenne, WY	
	11/30/2015	Hynds Lodge Restoration and Resiliency Project	Cheyenne, WY	
	11/30/2015	Hail Damage Repair Buffalo Court	Havre, MT	
<i>NEW</i>	12/1/2015	Sheridan College MARS Agriculture Center	Sheridan, WY	
<i>NEW</i>	12/1/2015	AML - Abandoned Mine Land Division Project 17.32-4 - Cheyenne	Cheyenne, WY	
	12/2/2015	Deadwood Welcome Center Project	Deadwood, SD	1
<i>NEW</i>	12/2/2015	Miner's Field at Copper Mountain Sports Park Lighting System	Butte, MT	
<i>NEW</i>	12/3/2015	Sweetwater County School District No. 1 - New Farson-Eden K-12 School	Rock Springs, WY	1
<i>NEW</i>	12/3/2015	Polleys Square Building B Bid Package 2	Missoula, MT	
<i>NEW</i>	12/4/2015	Montana Historical Society Modular in Drawer Shelving System	Helena, MT	
<i>NEW</i>	12/7/2015	Upgrade Lighting at the Fish Creek Campground Amphitheater - Glacier NP	Glacier National Park, MT	
	12/9/2015	Defense Access Road by Mile Stanford, Judith Basin County, Montana	Stanford, MT	
<i>NEW</i>	12/9/2015	WYDOT Highway Projects	Various, WY	
	12/10/2015	SD Department of Transportation Maintenance Shop Remodel and Addition	Faulkton, Sd	
	1/4/2016	Relocation and Rehabilitation of Hanager #5 - Bismarck	Bismarck, ND	
	3/21/2016	Gardiner Gateway PH 2 - ADVANCE NOTICE	Gardiner, MT	Online

**CONTRACTORS INFORMATION BUREAU— [www.CIBMONTANA.com](http://www.CIBMONTANA.com)**



**“INCREASE YOUR INDUSTRY and MARKET DISPOSITION”  
GET RESULTS ADDING YOUR PROJECTS, PRODUCTS & SERVICES**



# 3 LOCATIONS TO SERVE YOU

*Yeah, We Do That Too!*

**KALISPELL COPY CENTER**



406-755-5888 KALCOPY.COM  
2303 Hwy 2 East Kalispell

**Montana Plans Exchange**

## Helena Copy Center

406-457-2679 helenacopycenter.com  
1530 Cedar Street, Suite C • Helena, MT 59601

**Helena Plans Exchange**



(406)  
549-COPY



2304 McDonald Avenue  
Missoula, MT 59801

**WWW.MTCOPYCENTERS.COM**



## PLANS AVAILABLE

### RFP: LAND RECLAMATION, REHABILITATION, AND RE-VEGETATION SERVICES

FORT HARRISON

BIN:

ADDENDA: 1

BID DATE 11/9/2015

SCOPE: The STATE OF MONTANA, Department of Military Affairs Environmental Office ("State") is seeking to create a list of prequalified contractors to provide Land Reclamation, Rehabilitation, and Re-vegetation.

Limestone Hills Training Area just west of Townsend, Montana with approximately 18,500 acres and

Fort Harrison Training Area two miles west of Helena, Montana with approximately 7,000 acres

Owner: Montana Department of Environmental Quality, 1100 (406)444-6724  
Last Chance Gulch, Helena, MT 59620

### CRASH BLOCK REPAIR

SOUTH OF MELROSE, MT

BIN:

BID DATE 11/9/2015

SCOPE: PROJECT SITE: EAST SIDE OF THE UNION PACIFIC RAILROAD TRACKS, ON THE SOUTH SIDE OF BENT 5 OF THE NORTHBOUND BRIDGE, 40 MILES SOUTH OF BUTTE AND 7 MILES SOUTH OF MELROSE

ROUTE: I-15

MILEPOST: 86.32

BRIDGE ID #: 100015086+03271

#### 1.0. PROJECT DESCRIPTION

This project involves the repair of a concrete crash block located on the east side of the Union Pacific railroad tracks, on the south side of bent 5 of the north bound I-15 bridge at r.p. 86.32 (bridge ID # I00015086+03271).

The project is located 40 miles south of Butte, and 7 miles south of Melrose in Madison County, in Township 3 South, Range 9 west, Section 34.

The single crash block was impacted by a train derailment and pushed out of alignment. Repair the concrete crash block to restore the inside vertical face of the crash block to vertical. The finished vertical face is also to be in-plane with the bent 5, east column and the inside face of the other crash block on the north of this bent 5, east column. This work includes removing 126 square feet of concrete to a varying depth of 2" to 6" on the inside vertical face of the crash block, drilling and epoxying in new reinforcing, and replacing the removed and additional new concrete to the face of the crash block. Work will take place adjacent to active Union Pacific railroad tracks.

Owner: Montana Department of Transportation (Billings), 424 (406)657-0274 (406)256-6487  
Morey Street, Billings, MT 59104

**COLOR POSTERS UP TO 25ft!!!!**

2303 Hwy 2 East Kalispell, MT 59901 • [kalcop.com](http://kalcop.com) • 755-5888

Yeah, We Do That Too!

**KALISPELL COPY CENTER**



**PETE LIEN LIME PLAN WATER WELL - LARAMIE**

**LARAMIE, WY**

BIN: ADDENDA: 1  
BID DATE 11/9/2015 PREBID: 11-2 at 10AM Jonathon Quarry Haul Road (near mile marker 318 on U.S. Highway 30/287)

SCOPE: The proposed well site is located in Albany County, approximately 10 miles north of Laramie, Wyoming (Figure 1). The proposed well site is located in the northeast quarter of the southeast quarter of Section 9, Township 17 North, Range 73 West, on property owned by Pete Lien & Sons (PLS). The anticipated depth of the proposed well is 1,600 feet. The anticipated water-saturated thickness of the aquifer is at least 1,000 feet at the proposed site. Productive capacity of the well is desired to be 200 to 300 gallons per minute (gpm).

Engineer: Gorman Engineering , 1252 Commerce Drive, Laramie, (307)745-7474 WY 82070

**BLACK HILLS NATIONAL FOREST SUPERVISORS WAREHOUSE AND TRAILER**

**BLACK HILLS NATIONAL FOREST, SD**

BIN: ADDENDA: 1

BID DATE 11/9/2015

SCOPE: This project consists of two segments of work:  
1. WAREHOUSE BREAK ALCOVE CONSTRUCTION & OTHER FLOOR AND WALL IMPROVEMENTS  
? 60 DAY COMPLETION FROM NOTICE TO PROCEED  
2. SUPERVISOR'S WAREHOUSE OFFICE TRAILER

Issuing Office: Black Hills National Forest, 1019 N Fifth St , Custer, (605)716-1883 SD

**SHERIDAN AREA WATER SUPPLY BOOSTER STATION SCADA SYSTEM PROJECT**

**SHERIDAN, WY**

BIN: ADDENDA: 1

BID DATE 11/10/2015 PREBID: 10-29 10:00 a.m. local time, at the fourth floor of the Sheridan County Courthouse Addition, 224 S. Main Street Suite 428

SCOPE: Installation of a 900MHz radio-based SCADA System consisting of fourteen (14) remote RTU stations (located at existing SAWS booster stations), three (3) repeater stations, and one (1) Data Concentrator/Master station (located at the existing Sheridan Water Treatment Plant and integration into the existing City of Sheridan SCADA System.

Engineer: DOWL-HKM, 16 W 8th ST, Sheridan, WY 82801 (307)672-9006 (800)869-5984

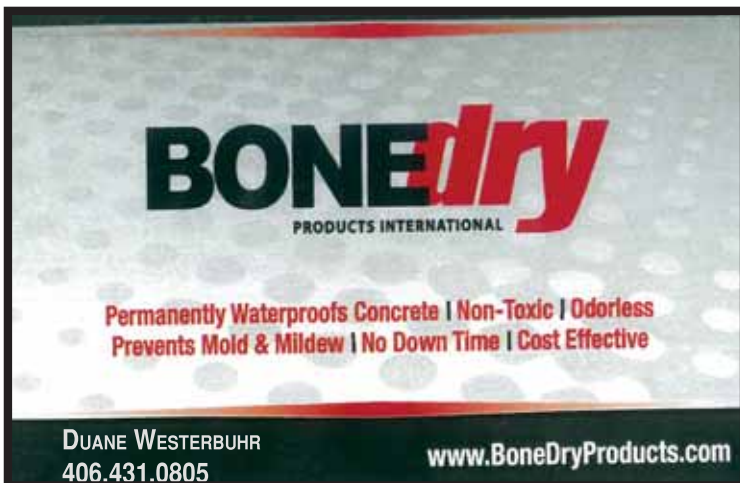

**TOWN OF BELT WATER METER INSTALLATION 2015**

**BELT, MT**

BIN:

ADDENDA: 1

BID DATE 11/10/2015

PREBID: Town Hall in Belt on 11/02/15 @10:00 a.m.

SCOPE: Any Contractor wishing to bid on this project must purchase a set of plans and specifications at NCI Engineering Co.

The work includes the installation of approximately 254 residential and commercial water meters. Meters will be provided by the Owner. The work will be completed within 60 calendar days;

Engineer: NCI Engineering, 4509 North Star Blvd, Great Falls, (406)453-5478 (406)453-2009 MT 59405

**RAPID TRANSIT BUS STORAGE FACILITY EXPANSION**

**RAPID CITY**

BIN:

ADDENDA: 2

BID DATE 11/10/2015

SCOPE: The Work consists of the removal of an existing 40 X 120 canopy and the construction of a concrete and steel addition for the storage of transit vehicles. Related site work includes remove and repair of concrete and asphalt paving, and the interfacing of controls.

Issuing Office: City of Rapid City, Rapid City, SD (000)000-0000

**OPI- MT DRIVE DRIVER TRAINING FACILITY**

**LEWISTOWN, MT**

BIN:

BID DATE 11/10/2015

SCOPE: Installation of a modular facility on a permanent foundation and all related work. Including but not limited to: Cast in place concrete, metal railings, plumbing and site work.

Architect: Praire Wind Architecture, 206 W Boulevard, Box 626, , (406)538-2201 (406)538-8989 Lewistown, MT 59457

# Western Building Centers

*Your locally owned  
lumber, building material  
& hardware supplier*

Kalispell  
755-6411  
Evergreen  
755-9444  
Whitefish  
862-2545  
Col Falls  
892-3204  
Eureka  
296-2253



Libby  
293-7755  
Ronan  
676-5726  
Polson  
883-5284  
Culbertson  
787-5880  
Stevensville  
777-1452

WBC Building Components - 892-2171

*“ Where the Contractor shops  
and so should you.”*

CertainTeed

# AirRenew<sup>®</sup> Essential

Our drywall not only makes homes look better, it makes them breathe & feel better. AirRenew<sup>®</sup> takes formaldehyde out of the air and keeps it out.

**NORTHWEST SUPPLY**  
**DRYWALL & ROOFING**

160 8th Ave WN • Kalispell, MT 59901  
406-752-2644 • www.nw-drywall.com

**CONSTRUCT MISSOULA COLLEGE - BID PACKAGE #3 –  
CULINARY ARTS EQUIPMENT**

---

**MISSOULA**

**BIN:**

**BID DATE** 11/10/2015

**PREBID:** October 20th, 2015 1:00 PM MST

**SCOPE:** A pre-bid conference is scheduled for Tuesday October 20th, 2015 @ 1:00 MST at the Missoula College Project Site – 1205 East Broadway. Missoula, MT 59802. After the site walk the group will proceed to the existing Missoula College East Campus facility to view/inspect the existing Equipment identified in the Bid Documents for potential relocation. The conference is not mandatory but highly recommended. Questions during the pre-bid conference will be recorded and distributed to all bidders through an Addendum. Meet at the Jackson Contractor Group, Inc. Site Office, 1205 East Broadway, Missoula, MT 59802. Remain in the site office until accompanied by a Jackson Contractor Group Representative. After the site walk the group will proceed to the Missoula College East Campus to view and inspect the Existing Equipment scheduled for potential relocation. Attendance is strongly recommended.  
Please ensure that you review the Div 00 - Invitation to Bid in its entirety. It contains specific procedures and the mandated format. Also included is the Bid Item Detailed Description which govern the indicated scope of work that must be included.

**General Contractor:** Jackson Contractor Group, 5800 Highway 93 South, Missoula, MT 59806 (406)542-9150 (406)542-3515

**ROUNDUP ELEMENTARY SCHOOL - FURNITURE  
INSTALLATION**

---

**ROUNDUP, MT**

**BIN:**

**ADDENDA:** 1

**BID DATE** 11/10/2015

**SCOPE:** Attached you will find a furniture package we would like to put out for bid for new furniture in the new Roundup Elementary School. Within the package is a layout of our bidding information and instructions, the furniture we would like to have priced, and the location of the installation of each piece (which should be included in the bid price. We will be going through the proposed bids on Tuesday November 10, 2015 at 3:00pm at our office.

**Architect:** Collaborative Design Architect, 2280 Grant Rd Ste C, Billings, MT, MT 59108 (406)248-3443 (406)248-3765

**FOUNTAIN SPRINGS COMMUNITY CHURCH – EAST CAMPUS  
RENOVATIONS**

---

**RAPID CITY, SD**

**BIN:**

**BID DATE** 11/12/2015

**SCOPE:** Bids will be received for various trades to include Concrete, Adhered Masonry Veneer, Structural Steel (Material and Installation), Rough Carpentry and Sheathing, Finish Carpentry (Material Only), Finish Carpentry (Installation Only), Exterior Insulation and Finish System (EIFS), Fully Adhered TPO (White) Single-Ply Membrane, Door and Hardware (Material Only), Door and Hardware (Installation Only), Aluminum-Framed Entrances, Storefronts, and Glazing, Drywall and Metal Framing, Tiling, Acoustical Panel Ceilings, Resilient Flooring and Carpeting, Painting and Coating, Specialties (Material Only), and Specialties (Installation Only).

**General Contractor:** Scull Construction Service, Inc., 803 Industrial Avenue, Meade, SD 57709 (605)342-2379 (605)342-8568

**CONSTRUCTION OF COMMUNITY SEWER IMPROVEMENTS ON  
THE YANKTON SIOUX RESERVATION**

**WAGNER, SD**

**BIN:**

**ADDENDA: 1**

**BID DATE** 11/12/2015

**SCOPE:** The Yankton Sioux Tribe will accept bids from qualified contractors for the construction of Community Sewer Improvements on the Yankton Sioux Reservation in Charles Mix County, South Dakota. The project generally consists of installing 175 feet of 8-inch PVC sewer main, 1 manhole, 154 feet of 4-inch PVC sewer service line, an individual lift station, 55 feet of directionally drilled 1.5-inch forcemain and 741 feet of trenched 1.5-inch force main. The total contract price will not be increased without prior authorization from the Owner via the change order process.

**Issuing Office:** Indian Health Service - Sioux City, 320 6th Street, Sioux (712)252-3988  
City, IA 51101

**HLRWSD HAYDEN LAKE COUNTRY CLUB LIFT STATION**

**HAYDEN, ID**

**BIN:**

**ADDENDA: 5**

**BID DATE** 11/12/2015      **PREBID:** Wednesday, October 21, 2015 at 10AM at the district office at 9393 Strahorn Road, Hayden Lake ID 83835

**SCOPE:** This project will consist of the construction of a new municipal sewage lift station. Key elements of the project include:  
Packaged duplex 40 HP suction lift pump station  
Precast concrete wet well  
Precast concrete overflow basins  
Standby generator  
Abandonment of existing lift station

**Engineer:** Welch Comer & Associates, Inc., 350 Kathleen Avenue, (208)664-9382 (208)664-5946  
Coeur d'Alene, ID 83815

**NEIGHBOR WORKS 1ST AVENUE ESTATES**

**GREAT FALLS, MT**

**BIN:**

**ADDENDA: 3**

**BID DATE** 11/12/2015      **PREBID:** 10-27 at 3:30 at L'Heureux Page Werner, 15th St S.

**SCOPE:** The project consists of a new 12 unit, three story apartment complex.

**Architect:** L'Heureux Page Werner, PC, 15 5th St. S, Great Falls, (406)771-0770 (406)771-0626  
MT, MT 59401

**UNIVERSITY OF MONTANA LIBERAL ARTS PHASE II REMODEL  
PROJECT NO. UM 15-63**

**MISSOULA, MT**

**BIN:**

**BID DATE** 11/12/2015      **PREBID:** Tuesday 11-3-15 at Liberal Arts Room 103B

**SCOPE:** Liberal Arts 103A/103B/204/205 Remodel Classrooms,

**Architect:** CTA Architects Engineers, 306 W. Railroad Ave., Suite (406)728-9522 (406)728-8287  
104, Missoula, MT 59802



**MISSOULA  
COPY CENTER**

2304 McDonald Ave.  
406-549-2679 • Fax 549-2697  
Email: missoulacopy@bresnan.net

**GRANDVIEW ELEMENTARY SCHOOL SHINGLE ROOF REPLACEMENT**

**RAPID CITY, SD**

BIN:

BID DATE 11/12/2015

PREBID: 11-5 1:20p.m. project Site

SCOPE: The project replaces approximately 5,000 sq. ft. of existing clay tile roof with new asphalt shingles at Grandview Elementary School. See the project plans and specifications for the scope of work.

Architect: Upper Deck Architects, Inc., 1301 W Omaha St, Ste 212, Rapid City, SD 57701 (605)721-0237 (605)721-0240

**HOT SPRINGS COUNTY MEMORIAL HOSPITAL MRI REMODEL - THERMOPOLIS**

**THERMOPOLIS, WY**

BIN:

ADDENDA: 1

BID DATE 11/12/2015 PREBID: MANDATORY 11-3 at 3PM at Hot Springs County Memorial Hospital, 150 E Arapahoe St

SCOPE: Concrete, cold-formed metal framing, miscellaneous metals, insulation, membrane roofing repairs, roof accessories, wood doors, hollow metal frames, Storefront sliding doors, hardware, glazing, gypsum board, acoustical panel ceilings, paint, signage, mechanical systems, plumbing, fire protection system, heating and ventilation, electrical systems, lighting and communications systems, excavation and backfill, rough grading, chain-link fences and all necessary appurtenances required to complete the work. Contractor to coordinate with Owner contracted companies – ETS-Lindgren(shielding company), Siemens(MRI) & MRI Depot, Inc. (removal of existing Phillips MRI).

Architect: Nelson Architects, LLC, 110 North 6th Street, Riverton, WY, WY (307)856-6155

**SOUTH WIND'S WATER SYSTEM REPLACEMENT**

**GREAT FALLS**

BIN:

ADDENDA: 1

BID DATE 11/12/2015 PREBID: 10-27 at 1:30PM Interested contractors are strongly encouraged to attend.

SCOPE: This project includes installation of well site access and grading, permanent water well pump, water storage tank, well house, yard piping and appurtenances, electrical service, water supply piping, water distribution and wastewater collection system piping replacement, water and wastewater service connections, and gravel surface restoration.

**\*\*Plans and Specs will be coming soon.\*\***

Engineer: NCI Engineering, 4509 North Star Blvd, Great Falls, MT 59405 (406)453-5478 (406)453-2009

**BILLINGS COMFORT SUITES**

**BILLINGS, MT**

BIN:

BID DATE 11/13/2015

Construction Manager: NorthRidge Construction, Inc., 1551 28th Ave South, Ste L, Grand Forks, MT 58201 (218)230-4170 (701)772-4428

BIN:

ADDENDA: 9

BID DATE 11/13/2015

- SCOPE: 001 Kaycee - Buffalo (Kaycee North/SBL) Leveling, Mill & Overlay  
Chad Aagard, P.E., Casper (307)473-3225 Grading, milling plant mix, placing crushed base and bituminous pavement surfacing, plant mix wearing course, reclaimed asphalt pavement, electrical, signing and miscellaneous work  
on 11.17 miles on I-25 beginning at RM 253.07 between Kaycee and Buffalo.
- 002 Hartville North Section (WYO 270) Leveling, Mill & Overlay  
Tim Rasnake, P.E., Wheatland (307)322-6500 Grading, milling plant mix, placing subbase and bituminous pavement surfacing, chip seal, reclaimed asphalt pavement widening, box beam guardrail and miscellaneous work on 10.87 miles on WYO 270 beginning just north of Hartville at RM 500.60.
- 003 Saratoga - Riverside (Snowy Range South) Mill & Overlay Jake Lonn, P.E., Rawlins (307)328-4103 Grading, milling plant mix, bituminous pavement surfacing, chip seal and miscellaneous work on 10.26 miles on WYO 130 beginning at RM 27.94 between Saratoga and Riverside.
- 004 Bryan Stock Trail (North Platte River Bridge) Structure Replacement  
Jack Stone, P.E., Casper (307)473-3227 Grading, draining, milling plant mix, placing crushed base, bituminous pavement surfacing, sidewalk, curb and gutter, removal and replacement of structure and miscellaneous work on  
0.12 mile on Bryan Stock Trail at the North Platte River Bridge.
- 005 Gillette Streets / Boxelder Rd (Overdale Dr - WYO 50) New Construction  
Joshua Jundt, P.E., Gillette (307)682-3550 Grading, removal and replacement of sidewalk, curb and gutter, placing crushed base, concrete pavement, water and sanitary sewer systems and miscellaneous work on 0.44 miles on Boxelder Rd in the City of Gillette.
- 006 Cody Streets (8th St. & Sheridan Ave.) Reconstruction Todd Frost, P.E., Cody (307)587-2220 Grading, milling plant mix, placing crushed base and bituminous pavement surfacing, plant mix wearing course, removal and replacement of sidewalk, curb and gutter, electrical and miscellaneous work on 1.14 miles US 14/16/20 beginning at RM 50.64 in the Town of Cody on 8th Street and Sheridan Ave.
- 007 Evanston - Green River (Lazart Jct Section) Miscellaneous  
Damon Newsome, P.E., Evanston (307)789-3363 Grading, draining, removal of surfacing, concrete slab replacement, guardrail and miscellaneous work on 14.85 miles on I-80 beginning at RM 12.65 between Evanston and  
Green River.
- 008 Sheridan Slide Repair (I-90 Median & Tank Farm Slide) Slide Repair  
Jerry Buckley, P.E., Sheridan (307)674-2326 Grading, draining, placing crushed base and bituminous pavement surfacing and miscellaneous work at various locations on I-90 and US 87 between Sheridan and Buffalo.

**DEMOLISH AND REMOVE OLD WATER TREATMENT PLANT -  
HURON**

**HURON, SD**

BIN:

BID DATE 11/16/2015

PREBID: 11-4 at oAM, contractor walk through on site

SCOPE: Specifications and proposal forms may be obtained from the City Engineer's Office.

Issuing Office: City of Huron, 239 Wisconsin Avenue SW, Huron, SD (605)353-8510  
57350

**MINOT AFB DESIGN-DRAINAGE, REPAVING, IMPROVEMENT  
RE-BID**

**MINOT, ND**

BIN: Online

ADDENDA: 6

BID DATE 11/17/2015

SCOPE: Work will include but is not limited to remove and replace the deteriorated asphalt pavement with a concrete pavement. Install a subsurface drainage system to remove excess ground water and stabilize the new pavement surface. Stoops and concrete aprons will be replaced using foundation walls to below frost depth. Other improvements include rebuilding the deteriorated POV parking area at building 531. Internal warehouse improvements to eye wash stations, fire suppression, heat, and lighting upgrades. Provide utility services to the buildings that do not have them for these improvements. Improve external security camera locations, site lighting levels, and truck access points to bring to standards.

Issuing Office: US Army Corp of Engineers, 106 South 15th Street, (402)995-2091  
Omaha, NE 68102

**CODY MEETINGHOUSE MURAL AND EXHIBIT IMPROVEMENTS**

**CODY**

BIN:

BID DATE 11/17/2015

PREBID: Subcontractor Site Walk and Pre-Bid Tuesday 11/3/15 at 1:30 PM at  
project site

SCOPE: Pay close attention to Schedule of Alternates. All contractors must be licensed in the city of Cody.

The Meetinghouse is an existing single story building over a crawlspace constructed of concrete, masonry and wood framing. It is assumed to be a Type III-B Construction, with A-3 and B Occupancy that doesn't change in use as a result of this project. There is no fire sprinkler system. Some existing systems are modified by the new design and some systems will be installed new in the work of this contract. Generally, the work includes interior remodeling of the exterior site around the south entrance, entrance and spaces adjacent to the entrance, Rotunda space with existing mural, portions of the existing circulation system and exhibit hall of the meetinghouse to prepare and coordinate the spaces for a complete installation of lighting and exhibits as documented by the Exhibit Designer. The Exhibit Designer (Gallagher and Associates) will release drawings in the future but their design is incomplete at the time of the release of the Construction Documents. The fabrication and installation of the exhibits by Pacific Studios and the Owner are not part of the work, but the General Contractor who is awarded this contract is responsible for coordination of the work performed by others to prepare the building for a complete installation of new exhibits

General Contractor: Wadman Corporation, 2920 South 925 West, Ogden, (801)621-4185 (801)621-7232  
UT



**MRA URD III S. RESERVE PED BRIDGE****MISSOULA, MT**

BIN:

BID DATE 11/17/2015 PREBID: MANDATORY 11-3 at 10AM at the City of Missoula Council Chambers,  
140 West Pine Street

SCOPE: This project consists of constructing a steel arch pedestrian bridge across South Reserve Street in Missoula, MT. Other work items contained in the contract include (4) steel truss approach spans; concrete bridge abutment, piers, and pile foundations; fiber reinforced polymer (FRP) heated bridge decking; concrete curb and gutter; concrete sidewalk; hot asphalt concrete pavement; sanitary sewer line relocation; water line relocation; lighting and electric utility service; pavement markings; fencing; temporary traffic control, and landscaping.

Engineer: DJA, P.C. (Missoula), 3203 Russell St, Missoula, MT, (406)721-4320 (406)549-6371  
MT 59801**PEDESTRIAN CROSSWALK SYSTEM-BASIN****BASIN, WY**

BIN:

BID DATE 11/17/2015

SCOPE: Pedestrian Crosswalk System with one side being a flashing beacon activated by a push button and the other side being a push button pedestal in accordance with the following specifications

Issuing Office: Wyoming Department of Transportation , 5300 Bishop Blvd, Cheyenne, WY (307)777-4487

**RIVERTON CENTRAL WYOMING COLLEGE STUDENT SUCCESS CENTER AND CAMPUS IMPROVEMENTS****RIVERTON, WY**

BIN:

BID DATE 11/17/2015 PREBID: MANDATORY 11-3 10A.m. Central Wy College Center Bldg rm125

Architect: Plan One Architects, 1001 12th St, Cody, WY 82414 (307)587-8646 (307)587-8366

Owner: Department of Administration and Information, 700 West 21st Street, Cheyenne, WY (307)777-6708 (307)777-6708

**OFFICE & MAINTENANCE SHOP ADDITION AND REMODEL - SD DOT - ARMOUR SD****ARMOUR, SD**

BIN:

BID DATE 11/17/2015 PREBID: 11-4 10:00 AM, Armour, South Dakota at the site.

SCOPE: This Project Manual provides for liquidated delay damages in the amount of \$250.00 per calendar day for the Contractor's delay in completion of the work. See the Bid Form, Agreement for Construction, and Article 10 of the General Conditions for details.

Architect: RS Architects, 2307 W 57th St Ste 201, Sioux Falls, SD, (605)336-6891 (605)336-5858  
SD 57104**LARGE FORMAT  
POSTERS**755-5888  
KALCOPY.COM  
2303 Hwy 2 East  
Kalispell, MT 59901

Yeah, We Do That Too!

**KALISPELL COPY CENTER**

**RFQ- NORTH SEVENTH URBAN RENEWAL DISTRICT  
ENGINEERING SERVICES, CITY OF BOZEMAN**

**BOZEMAN, MT**

**BIN:**

**BID DATE** 11/17/2015

**SCOPE:** The City intends to develop a 3 year term contract with the selected firm to provide engineering services for the NSURD including but not limited to those described in the Scope of Services document. The work may be broken into several projects over multiple fiscal years and may require the submission of proposed scopes of work as requested by staff.

**Owner:** City of Bozeman, 20 East Olive, Bozeman, MT 59715 (406)582-2264 (406)582-3232

**HELENA HIGH SCHOOL GYM RE-ROOF**

**HELENA, MT**

**BIN:**

**BID DATE** 11/18/2015

**PREBID:** 11-10 3:30P.M. at CWG Architects Office 650 Power Street

**SCOPE:** Construction for this re-roofing work includes but is not limited to the removal of the existing asphalt shingle, built up asphalt roofing, vapor barrier, insulation down to plywood deck and the installation of a new vapor barrier, insulation, recovery board, membrane roof, flashing at eaves and pipe penetrations, expansion joint and diverters over the current plywood and 3'-1.2" T & G decking per the drawings and specifications.

Contractors to provide a line item cost/square foot for potential replacement of wood decking. An inspection will be done following the demolition to determine existing conditions. Quantities may vary but an estimated square footage is 220 S.F. for areas in and around the existing infilled skylights.

**Architect:** CWG Architects, Helena, MT 59624 (406)443-2340 (406)442-8565

**FAITH HOME - HEATING SYSTEM REPLACEMENT, WOLF POINT**

**WOLF POINT, MT**

**BIN:**

**ADDENDA:** 1

**BID DATE** 11/19/2015

**Prebid:** NOVEMBER 11, 2015 AT 11 A.M.

**SCOPE:** Work for this project will consist of complete replacement of the building steam heating system. The replacement will include piping, boilers, individual room heating units and space controls. As a portion of the project limited general construction work will be required. Work includes all labor, materials, equipment and services for the removal of the existing equipment; the installation of new equipment complete including controls, piping, boiler stack, gas and electrical service; testing, adjusting and balancing. Buildings shall be restored to better than existing condition (finishes). Work associated with the project includes the following: All demolition work shown in the affected areas. Proper waste disposal and recycling efforts. Extending the building's electrical services to support the new work.

**Engineer:** Con'er Engineering, 1629 Avenue D, Ste 7-C, Billings, MT 59102 (406)252-3237 (406)252-3276

**COLOR POSTERS UP TO 25ft!!!!**

Yeah, We Do That Too!

**KALISPELL COPY CENTER**

755-5888 • KALCOPY.COM  
2303 Hwy 2 East • Kalispell, MT 59901

**BENEFIS PHARMACY & RESPIRATORY THERAPY REMODEL****GREAT FALLS**

BIN:

BID DATE 11/19/2015                      PREBID: MANDATORY Nov 3rd at 10AM- See Scope of work for details

SCOPE: This remodel entails the complete renovation of a portion of the existing 4th floor in what was once the Intensive Care Unit and support offices at Benefis Health System East Campus. This project will provide for a new hospital Pharmacy suite (6,180 SF) and a new Respiratory Therapy department (2,280 SF). Including the connecting corridor (635 SF) the entire remodel involves 9,095 SF of renovated space on the 4th floor. The entire space is fully sprinklered and will host approximately 55 workers in the Pharmacy area and 60 workers in Respiratory Therapy. An existing elevator that serves this area will be completely upgraded with a new traction elevator system to handle the new vertical circulation loads inherent with this departmental relocation. A mandatory pre-bid conference will be held for all interested General Contractors, HVAC, Plumbing and Electrical Sub-Contractors at 10:00 AM local time on the 3rd day of November, 2015, at Benefis Health System, East Campus in Classroom 4 located at 1101 26th Street South, Great Falls, Montana 59405. **GIVEN THE NATURE OF THIS PROJECT, ATTENDANCE AT THIS MEETING BY THESE TRADES IS A REQUIREMENT TO SUBMIT A BID.**

Architect: Nelson Architects, 621 2nd Avenue North, Great Falls, (406)727-3286 (406)770-3088 MT 59401

**MRI BUILDING -CHEYENNE, WY****CHEYENNE, WY**

BIN:

ADDENDA: 5

BID DATE 11/19/2015                      PREBID: 9-10 9:30A.M. Site Visit Attendees will meet Cheyenne VA Medical Center

SCOPE: The Cheyenne Veteran Affairs Medical Center (VAMC) in Cheyenne, Wyoming has a requirement to construct a new 3,346 square foot MRI Building in accordance with all drawings, specifications, and scope of work, which will be posted with the request for proposal. The NAICS code for this procurement is 236220 with a small business size standard of \$36.5 M. The magnitude of this project is between \$1,000,000 and \$2,000,000. This project will be 100% set-aside for Service-Disabled Veteran-Owned Small Businesses, as stated below.

Issuing Office: Department of Veterans Affairs, 4100 E Mississippi Ave, STE 1110, Glendale, CO 80246 (303)504-2693

**NORTH MIDDLE SCHOOL ROOF REPLACEMENT****RAPID CITY, SD**

BIN:

BID DATE 11/19/2015                      PREBID: 11-10 1:30pm Project Site

SCOPE: The Project consists of the reroofing approximately 64,450 sq. ft. of the existing North Middle School

Architect: Upper Deck Architects, Inc., 1301 W Omaha St, Ste 212, Rapid City, SD 57701 (605)721-0237 (605)721-0240

**POSTERS UP TO 25ft!!!!**

Yeah, We Do That Too!

**KALISPELL COPY CENTER**

755-5888  
**KALCOPY.COM**  
 2303 Hwy 2 East  
 Kalispell, MT 59901

**DENNISON THEATRE LIGHTING UPGRADE, UNIVERSITY OF  
MONTANA, MISSOULA**

**MISSOULA, MT**

**BIN:**

**BID DATE** 11/19/2015

**PREBID:** Nov 10th 2:00 pm at Dennison Theater

**SCOPE:** A PRE-BID WALK-THROUGH IS SCHEDULED FOR TUESDAY, NOVEMBER 10, 2015, AT 2:00 P.M. PARTICIPANTS SHOULD MEET AT THE DENNISON THEATRE ON THE UM CAMPUS IN MISSOULA. ATTENDANCE IS STRONGLY RECOMMENDED.

**Engineer:** Fussell Engineering, 3700 S Russell St, Ste 106, (406)721-6996  
Missoula, MT 59801

**BLACK PINE MINE RECLAMATION CONSTRUCTION -  
PHILLIPSBURG**

**PHILLIPSBURG, MT**

**BIN:**

**ADDENDA:** 3

**BID DATE** 11/19/2015 **PREBID:** MANDATORY on October 29, 2015. The preconference will convene at 10:00 a.m. Mountain Time at the repository location at Project Site

**SCOPE:** Bids will be received for one General Contract. Multiple hazardous features and waste remain at the Site including abandoned adits and shafts, two historical mills, modern mill buildings, and mine wastes. A repository has been excavated to contain impacted solid media waste. Contractor will provide water; install construction Best Management Practices (BMP's); construct a run-on ditch upgradient of the repository footprint; excavate, haul, place and compact waste rock and tailings from around the site within the repository footprint; construct the repository cover; haul and backfill embankment or cover soil at tailings and waste rock removal areas ; reconstruct Mill Creek and install streambank protection in South Fork Lower Willow Creek; revegetate disturbed areas; and remove debris items after completion. Work will include all incidentals necessary to complete the project as specified in the Contract Documents. The Black Pine Mine (Site) is approximately 10 miles northwest of Philipsburg, Montana off Highway 1 in Granite County within Sections 16 and 17 of Township 8 North and Range 14 West, Montana Principal Meridian. A pre-bid conference will be held for prospective bidders on October 29, 2015. The preconference will convene at 10:00 a.m. Mountain Time at the repository location at Project Site. The pre-bid conference will be followed immediately by a walk-through of the work areas on the site. Directions to the site are set out at Project Location above. Both the pre-bid conference and the walk-through are mandatory: bidding contractors are required to attend. Failure to attend the pre-bid conference and walk through is a basis for Owner to reject the bid under Article 5 of the Instruction to Bidders.

**Owner:** Montana Department of Environmental Quality, 1100 (406)444-6724  
Last Chnace Gulch, Helena, MT 59620

**COLOR POSTERS UP TO 25ft!!!!**

**Yeah, We Do That Too!**

**KALISPELL COPY CENTER**

2303 Hwy 2 East Kalispell, MT 59901 • [kalcopy.com](http://kalcopy.com) • 755-5888

**GLENDO STATE PARK-SANDY BEACH CAMPSITE ELECTRICAL PROJECT**

**PLATTE COUNTRY, WY**

**BIN:**

**BID DATE** 11/19/2015

**PREBID:** 11-5 1p.m. Sandy Beach Dune Shelter

**SCOPE:** Completion of an on-site investigation of existing conditions, furnish all labor, equipment, supplies and materials in performing all operations necessary for the complete and proper installation of new 50 amp RV pedestals for a feasible number of the existing 22 single and 7 group campsites above the high water mark at Sandy Beach Dune Campground at Glendo State Park, with alternate locations in Willow Campground and lighting outside restrooms and all work necessary to complete these tasks, as indicated in these contract documents.

**Architect:** TDSi - The Design Studio, Inc., 1906 Thomes Avenue, (307)775-9970 (307)775-9946  
Cheyenne, WY 82001

**VISCOM PHOTO CLASSROOM RENOVATION MSU BOZEMAN**

**BOZEMAN, MT**

**BIN:**

**BID DATE** 11/19/2015

**PREBID:** 11-9 4p.m. meet at visual communications bldg grant Street

**SCOPE:** Nine of the dark rooms will be decommissioned, walls demolished to provide a single space capable of housing less demanding "dim room" as well as instructional space for up to 20 students. Photography sinks are to be provided on one side of the room, with digital processing computers and printers on the other, leaving the central part of the room open for seminar use. The space is designed to accommodate accessibility needs and provide projection display. The space will be provided with upgraded mechanical and electrical systems including exhaust ventilation, improved plumbing facilities, dimmable lighting and power for equipment.

**Issuing Office:** Montana State University - Facilities Planning Dept, 6th Ave and Grant Street, Bozeman, MT 59717 (406)994-5413 (406)994-5665

**LANDSCAPING SHERIDAN VAMC, WYOMING**

**SHERIDAN**

**BIN:**

**BID DATE** 11/19/2015

**SCOPE:** Contractor shall provide all labor, equipment, materials and supervision necessary to perform all work required for this project in accordance with all drawings, specifications, and the scope of work. The project is located at the Sheridan VA Medical Center at 1898 Fort Road Sheridan, Wyoming 82801.

**Issuing Office:** Department of Veterans Affairs, 4100 E Mississippi Ave, STE 1110, Glendale, CO 80246 (303)372-7017



**FAST COLOR COPIES**

Yeah, We Do That Too!

**KALISPELL COPY CENTER**

**2303 Hwy 2 East Kalispell, MT 59901**

**KALCOPY.COM**

**KEMMERER RECREATION CENTER RE-ROOF****KEMMERER, WY**

BIN:

BID DATE 11/19/2015

SCOPE: Removal of existing roofing system, including rock ballast, EPDM membrane and base flashings. All materials to be removed from site. Existing Metal Coping Cap to be removed, stored and protected for re-use. If applicable, removal and disposal of ACM (Asbestos Containing -Roofing Materials) and ACM (Asbestos Containing Construction Materials) the flashing shall be according to all applicable federal, state and local standards, including but not limited to EPA and OSHA standards.

Issuing Office: City Clerks Office -Kemmerer, 220 Wyoming Highway (307)727-7865  
233, Kemmerer, WY 83101

**DAKOTA/ATHLETIC/HPER DOME RENOVATION & OFFICE SHELL SPACE****VERMILLION, SD**

BIN:

BID DATE 11/19/2015

PREBID: 11-10 at 9:30AM at the work site East door entrance.

SCOPE: Combined Bids will be received for fitout and finishing of athletic offices shell space in new basketball/volleyball arena including all necessary work.

Issuing Office: South Dakota Office of State Engineer, 523 East (605)339-1711  
Capitol, Pierre, SD 57501

**LINCOLN ROAD REQUEST FOR PROPOSAL - ENGINEERING SERVICES****HELENA**

BIN:

BID DATE 11/19/2015

SCOPE: The Montana Department of Transportation is accepting proposals from consulting firms interested in the preparation of the construction plans and specifications for Lincoln Road.

Owner: Montana Department of Transportation (Billings), 424 (406)657-0274 (406)256-6487  
Morey Street, Billings, MT 59104

**ELEVATOR MAINTENANCE AND REPAIR - BHHCS****FORT, SD**

BIN:

BID DATE 11/19/2015

SCOPE: The Department of Veterans Affairs Network 23 Contracting Office (NCO 23), on behalf of the VA Black Hills Health Care System (VA-BHHCS) at 113 Comanche Road, Fort Meade, SD 57741, contemplates issuing a Request for Proposal (RFP) to award a single, firm fixed-price contract for Elevator Maintenance and Repair Services for both the Fort Meade and Hot Springs Facilities of the VA-BHHCS. The performance period will be from time of contract award through end of the 1-year base period, followed by four, 1-year option periods.

Issuing Office: Department of Veteran Affairs VA Black Hills HCS, (605)720-7314  
Fort Meade Campus 113 Comanche Rd, Fort Meade,  
SD

**COLOR PLOTS AND POSTERS**

Yeah, We Do That Too!

**KALISPELL COPY CENTER**

KALCOPY.COM

755-5888 2303 HWY 2 EAST KALISPELL MT 59901

**MDOT - SF 129 - ITS/VMS ROGERS PASS****ROGERS PASS, MT**

BIN:

BID DATE 11/19/2015

SCOPE: Roadway and roadside improvements on the SF 129 - ITS/VMS Rogers Pass project in Lewis and Clark County. The project is located on MT-200 beginning at RP 90.0 to 91.0 (the first mile of roadway immediately northeast of Rogers Pass).

Issuing Office: Montana Department of Transportation, Room 101, (406)444-6216 (406)444-7236  
2701 Prospect Ave, Helena,, Helena Lewis and Clark,  
MT 59620

**MDOT - RESERVATION CREEK - E AND W****ROSEBUD COUNTY, MT**

BIN:

BID DATE 11/19/2015

SCOPE: Seal and cover, crack seal, bridge rail and deck repair on the Reservation Creek - E and W (EB and WB) project in Rosebud County.  
The project begins at RP 78.3 (Treasure/Rosebud County line) on Interstate 94 and proceeds east  
5.4 miles to RP 83.7, the project end.

Issuing Office: Montana Department of Transportation, Room 101, (406)444-6216 (406)444-7236  
2701 Prospect Ave, Helena,, Helena Lewis and Clark,  
MT 59620

**MDOT - 7TH AVE ADA RAMPS - LEWISTOWN****LEWISTOWN, MT**

BIN:

BID DATE 11/19/2015

SCOPE: Sidewalk and ADA upgrade work on the 7th AVE ADA Ramps - Lewistown project in Fergus County. The project is located in Lewistown along a 12 block section of 7th Avenue from Broadway Street to 1st Street.

Issuing Office: Montana Department of Transportation, Room 101, (406)444-6216 (406)444-7236  
2701 Prospect Ave, Helena,, Helena Lewis and Clark,  
MT 59620

**GENERATOR EXCITATION SYSTEMS FOR BIG BEND DAM, SD****BIG BEND, SD**

BIN:

ADDENDA: 3

BID DATE 11/20/2015

SCOPE: The scope of work for this contract consists of the Contractor furnishing all supervision, engineering, labor, materials, and equipment to perform the following work in strict accordance with the detailed requirements of this contract.

Issuing Office: US ARMY CORPS OF ENGINEERS, 1616 Capital Ave, Omaha, NE 68102 (402)995-2045 (000)000-0000



Yeah, We Do That Too!

**KALISPELL COPY CENTER**

**COLOR POSTERS**

WWW.KALCOPY.COM

406-755-5888  
Fax: 755-5896

2303 Hwy 2 East  
Kalispell, MT 59901

**2016 HOLIDAY BOOSTER STATION ELECTRICAL UPGRADES  
AND IMPROVEMENTS PROJECT - SPEARFISH, SD**

**SPEARFISH, SD**

**BIN:**

**BID DATE** 11/20/2015      **PREBID:** 11-10 at 12:30PM at the Holiday Booster Station, 705 Colorado Blvd

**SCOPE:** The City of Spearfish, South Dakota is pre-qualifying firms for a design-build project for the 2016 Holiday Booster Station Electrical Upgrades and Improvements Project which consists of replacement of existing motor control panels, upgrade to variable frequency drives on certain pumps and a replacement of all wiring inside the building from the service entrance. The contractor shall design and install new equipment, remove and salvage existing equipment, and provide a two-year warranty.

**Issuing Office:** City of Spearfish, 625 Fifth Street, Spearfish, SD      (605)642-1333  
57783

**WASTEWATER TREATMENT IMPROVEMENTS WWTP  
UPGRADES DEER LODGE**

**DEER LODGE, MT**

**BIN:**

**BID DATE** 11/23/2015      **PREBID:** 11-02 9 a.m Deer Lodge City Hall, 300 Main St

**SCOPE:** Construction of a new wastewater treatment plant including:

- o Preliminary treatment (screening and degritting);
- o Influent lift station;
- o Activated sludge treatment in three bioreactor trains;
- o Secondary clarification in two (plus 1 additive alternate) clarifiers;
- o UV disinfection;
- o Aerobic digestion, sludge dewatering and storage;
- o Buildings and equipment appurtenant to these processes;
- o Site access improvements, including a new access road and bridge over the Kohrs-Manning ditch;
- o Potable water well.

Additional Information:: This project is on QuestCDN. Complete electronic Project Plans, Project Specifications, and Bid Proposal Packet are available at the Morrison-Maierle, Inc. website <http://www.m-m.net/> click on the "Project Bidding" tab, then "Browse Current Projects" and select this project from the project list. Documents can only be viewed on the Morrison-Maierle, Inc. website, and cannot be downloaded or printed without purchasing. To purchase and download the project documents in pdf format, click "Download Project PDF" and sign on to <https://www.questcdn.com/> or join for a free membership. Plan documents can be downloaded for a fee of \$60. Please contact QuestCDN at 952-233-1632 or email "info@questcdn.com" for assistance in the free membership registration, downloading, and working with this digital project information.

**Engineer:** Morrison-Maierle, Inc.,, 1 Engineering Place, Helena,      (406)442-3050      (406)442-7862  
MT 59604

**KALCOPY.COM**

*Yeah, We Do That Too!*

**KALISPELL COPY CENTER**

**COLOR PLOTS AND POSTERS**

**2303 Hwy 2 East Kalispell, MT 59901**



**RFQ - ARCHITECTURAL, ENGINEERING, PLANNING AND  
CONSULTANT SERVICES FOR AIRPORT GRANT PROJECTS**

**RAPID CITY, SD**

**BIN:**

**BID DATE** 11/24/2015

**SCOPE:** The Rapid City Regional Airport Board is issuing an RFQ to provide the opportunity for all interested and qualified Consultants to submit a Statement of Qualifications. The successful Consultant shall provide 1) project design services; 2) final project layout based on 2015 Master Plan; 3) CIP and PFC assistance; 4) construction management services; 5) grant development/processing; and 6) post project as-built GIS updates.

**Issuing Office:** Rapid City Regional Airport, 4550 Terinal Road Suite (605)394-4195  
102, Rapid City, SD 57703

**WESTERN MONTANA CLINIC- NOW CARE RELOCATION -  
SOUTHGATE MALL - MISSOULA**

**MISSOULA, MT**

**BIN:**

**ADDENDA:** 1

**BID DATE** 11/24/2015

**PREBID:** 11-4 at 9am on site

**SCOPE:** Demo of two existing Southgate Mall tenant units (Nailtrix & Payless Shoes) which will be remodeled into one tenant unit for Western Montana Clinic. Work includes mall corridor façade remodel, waiting room, reception, exam rooms, lab, x-ray room, nurse's station, office, break room, restrooms, and accessory spaces. The remodel includes wall framing, cabinetry, flooring by owner, mechanical, electrical and plumbing. This project is an invited bid project.

General contractors selected to bid are as follows:

- Quality Construction  
2800 Reserve Street  
Missoula, MT 59801  
Contact Flint Olsen, 728-0080
- Jackson Contractor Group  
5800 US Highway 93  
Missoula, MT 59804  
Contact Mark Kobos, 542-9150
- Gooden Construction  
16862 Beckwith St.  
Frenchtown, MT 59834  
Contact Wade Gooden, 626-0840

- |                            |   |               |               |
|----------------------------|---|---------------|---------------|
| <b>Architect:</b>          | MacArthur, Means, Wells Arch, 125 W Alder Street,<br>Missoula, MT 59802   | (406)543-3928 | (406)327-9367 |
| <b>General Contractor:</b> | Gooden Construction, Inc., 16862 Beckwith Street,<br>Frenchtown, MT 59834 | (406)626-0840 | (406)626-5367 |
| <b>General Contractor:</b> | Jackson Contractor Group, 5800 Highway 93 South,<br>Missoula, MT 59806    | (406)542-9150 | (406)542-3515 |
| <b>General Contractor:</b> | Quality Construction Company, 2800 South Reserve,<br>Missoula, MT 59806   | (406)728-0080 | (406)542-3639 |

2303 Hwy 2 East Kalispell, MT 59901 • [kalcop.com](http://kalcop.com) • 755-5888



**POSTERS UP TO 25ft!!!!**

Yeah, We Do That Too!

**KALISPELL COPY CENTER**

**CASCADE COUNTY COPPER ROOF REPLACEMENT****GREAT FALLS, MT**

BIN:

BID DATE 11/24/2015 PREBID: 10/27/2015, 1:30 PM - in the Commission Chambers Room 111 of the Courthouse Annex at 325 2nd Avenue North, Great Falls

SCOPE: The Scope of Work, in brief, consists of, but is not limited to the removal and in-kind replacement of the existing copper roof finish of the dome, hip roof, and parapet, preparation and installation of EPDM liner to existing built-in gutters, removal and in-kind replacement of wood sheathing, sandstone repointing, sandstone patching, cast iron disassembly and reassembly, in-kind window replacement, painting, and limited EPDM roof installation to the National Register Listed Cascade County Courthouse located at 415 2nd Avenue North, Great Falls, Montana, 59401. Work includes removal of asbestos-containing materials and lead-in-paint in extents necessary to perform the work indicated in accordance with TD&H Engineering's Revised Limited Pre-Renovation Asbestos and Lead-in-Paint Inspection Report dated September 25, 2015 included in the Project Manual. Work of this Project includes all indicated and incidental demolition, including transportation, disposal, storage, containment of and housekeeping activities involving abatement of asbestos and products containing asbestos and lead base paints, protection and construction required due to Work indicated or required for the Work indicated and the Owner and public's continued occupancy and access to the building.

Architect: A &amp; E Architects, 222 North Higgins Ave., Missoula, (406)721-5643 (000)000-0000 MT 59802

**CONSTRUCTION MANAGER AT RISK FOR ADDITIONS & RENOVATIONS TO WASTE TRANSFER STATION - CHEYENNE****CHEYENNE, WY**

BIN:

ADDENDA: 1

BID DATE 11/24/2015 PREBID: MANDATORY 11-10 at 2 PM at the Cheyenne Waste Transfer Station, 200 N. College Dr

SCOPE: The City of Cheyenne ("City") is seeking a qualified Construction Manager at Risk ("CMAR") to provide Pre-Construction and Construction Phase services for Phases two (2) and three (3) of a Project entitled "Additions and Renovations to the City of Cheyenne Waste Transfer Station." This Project is a three phase construction project at the City's Waste Transfer Station located at 200 N. College Dr., Cheyenne, WY. Phase 1 was completed in 2015 and included construction of a new Household Hazardous Waste ("HHW") facility, site work at the HHW building, and preparatory work for Phases 2 and 3.

Owner: City of Cheyenne, Cheyenne, WY 82001 (307)637-6294

**HILL COUNTY COURTHOUSE EXTERIOR ENVELOPE RESTORATION****HAVRE, MT**

BIN:

BID DATE 11/24/2015

SCOPE: The Scope of Work, in brief, consists of, but is not limited to, terra cotta cleaning, restoration and repointing of the exterior terra cotta finish to the National Register Listed Hill County Courthouse located at 315 4th Street, Havre, Montana, 59501. Work includes all indicated and incidental demolition, protection, and construction required due to Work indicated or required for Work indicated and the Owner's continued occupancy of the building.

Architect: A &amp; E Architects, 222 North Higgins Ave., Missoula, (406)721-5643 (406)721-1887 MT 59802

**COOLING EQUIPMENT REPLACEMENT FT. HARRISON,  
MONTANA**

**FORT HARRISON, MT**

**BIN:**

**ADDENDA: 1**

**BID DATE 11/25/2015**

**PREBID: 11-4 9a.m. Building 141, Room 205, at the Ft. Harrison VA Medical Center in Montana**

**SCOPE:** The Ft. Harrison Veterans Affairs Medical Center (VAMC) in Fort Harrison, Montana has a requirement to replace the existing chiller and provide a secondary chiller for redundancy in the operating rooms and associated surgical/sterile areas. Contractor shall provide all construction services, materials, labor, alterations to roads, walks, grading, drainage, mechanical and electrical work, and utility systems, necessary for removal of the existing aging chiller serving the operating rooms and to provide redundancy by replacing the aging chiller with a 3 chiller system piped in parallel. All work will be accomplished on the Ft. Harrison VA Medical Center campus as indicated in the specifications, drawings and statement of work under project number 436-15-09. The NAICS code for this procurement is 238220 with a small business size standard of \$15M. The magnitude of this project is between \$1,000,000 and \$2,000,000. This project will be 100% set-aside for Service-Disabled Veteran-Owned Small Businesses, as stated below.

**Issuing Office:** Department of Veterans Affairs, 4100 E Mississippi Ave, STE 900, Glendale, CO 80246 (303)372-7088

**REPAIR MAF WINDOWS, INSULATION, SIDING - MALMSTROM  
AFB - GREAT FALLS**

**MALMSTROM AFB, MT**

**BIN:**

**BID DATE 11/25/2015**

**SCOPE:** The purpose of this project is to allow continuous operations of the Missile Alert Facility while providing a complete replacement of the exterior siding, replace waste lines under the bathroom floor(s), replace existing bathroom floors with concrete floors with radiant heat, replace existing HVAC system, enlarge the FSC bathroom replacing penal fixtures with traditional, enhance cooling in the kitchen, provide new insulation and windows for the exterior walls with the exception of the Security Office, provide adequate low voltage electrical capability to support the current power requirements in the exercise room and to allow for future increased requirements by expanding the LCB panel in the 103 room, provide adequate insulation in the attic space and freedom of movement in/ through the MAF attic space to comply with current Air Force design standards, Headquarters Global Strike Command design directives, Base standards, referenced publications and Montana DEQ requirements at 15 Missile Alert Facilities (MAFs).

**Issuing Office:** 341 st Contracting Squad Dept of the Air Force- Contracting MAFB, 7015 Goddard Dr Bldg 145, Malstrom AFB , MT 59402

(406)731-4111 (406)731-4005

**POSTERS UP TO 25ft!!!!**

*Yeah, We Do That Too!*

**KALISPELL COPY CENTER**

2303 Hwy 2 East Kalispell, MT 59901 • [kalcop.com](http://kalcop.com) • 755-5888

BIN:

BID DATE 11/30/2015

SCOPE: Design Development level information is provided with this RFQ that broadly identifies the scope of Historic Wood Window Restoration. The Historic Wood Window Restoration subcontract will include the following major scopes of work:

Windows:

Approximately 323 window openings. Quantity to be verified by subcontractor.

1. Reuse of existing (restored) frames including lead paint abatement and refinishing of frames.
2. Design of replication window frames shall be consistent with historic profiles.
3. Frames shall be wrapped in extruded aluminum panning which matches historic profiles.
4. New wood sashes with fixed upper sashes and operable lower sashes.
5. Removal of existing aluminum window panning, aluminum window sashes and disposal at onsite dumpsters provided by contractor. Abatement by others.
6. Restore and repair frames and install custom aluminum panning with profiles to match existing frames and sills to encase existing wood frame windows.
7. Restore and repair frames and sills using liquid epoxies and epoxy fillers. Damaged wood members that are beyond repair are to be replaced with exact replicas. Wood sills and frames shall be sanded smooth in preparation for finishing.
8. Include final finish. Sash: painted exterior with stained or painted interior. Aluminum Panning: Kynar finish.
9. Restored and replicated windows shall support the additional weight of new laminated glass. Add steel as required.
10. Include new lead weights, pulleys and modifications to weight pockets as necessary.
11. Include application of new perimeter sealants between brick mould and masonry.
12. Include installation of new weather-stripping as required for the upper and lower window sashes.
13. Wood species shall be Cherry to match existing.
14. Bullet Proof Glass installation at windows within the Governor's Suite.

Hardware:

1. All hardware provided shall be historically sympathetic to the original hardware.
2. Sash lifts
3. Checkrail locks
4. Sash stop grommets
5. Chains, pulleys and lead weights
6. 5/8" Clear Annealed Insulated Glass. Note: many windows are low to the floor and require code compliant safety glass.

General Contractor: JE Dunn, Portland, OR 97217

(303)782-7338

**MISSOULA  
COPY CENTER**

2304 McDonald Ave.  
406-549-2679 • Fax 549-2697  
Email: missoulacopy@bresnan.net



**Helena Copy Center**

---

406-457-2679 • Fax 406-457-0226  
1530 Cedar Street, Suite C • Helena, MT 59601  
planex@helenacopycenter.com • www.MontanaPlansExchange.com

Helena Plans Exchange

**HYNDS LODGE RESTORATION AND RESILIENCY PROJECT****CHEYENNE, WY**

BIN:

BID DATE 11/30/2015

SCOPE: PROJECT DESCRIPTION: See Attachment B, This project has five (5) blocks. Blocks are not marked. The primary tree species is ponderosa pine.

ACCESS: From the Cheyenne I-25 exit 10D take state highway #210 west towards Curt Gowdy State Park. Continue west on highway #210 approximately 24 miles to the Hynds Lodge Road, take a right and continue 0.2 miles

north on the Hynds Lodge Road to project area. From the Sherman Summit I-80 exit #323 take state highway #210, continue east on highway #210 approximately 15 miles to the Hynds Lodge Road, take a right and continue 0.2 miles north on the Hynds Lodge Road to project area. See attached Project Area Map (Attachment A) and Vicinity Map (Attachment C).

Issuing Office: Department of Administration and Information, 700 West 21st Street, Cheyenne, WY 82002 (307)777-6708 (307)777-6708

**HAIL DAMAGE REPAIR BUFFALO COURT****HAVRE, MT**

BIN:

BID DATE 11/30/2015

SCOPE: Buffalo Court Lp is accepting Bids for the repair of Hail Damage to the Roofs, Gutters and Downspouts on 5 buildings.

Issuing Office: Buffalo Court LP, Havre, MT, MT 59501 (406)265-6743

**SHERIDAN COLLEGE MARS AGRICULTURE CENTER****SHERIDAN, WY**

BIN:

BID DATE 12/1/2015 PREBID: 11-12 at 1PM meet in the Science Center Lobby on the campus at Sheridan College, 3059 Coffeen Ave.

SCOPE: New construction: deep foundation systems, concrete foundations, waterproofing, foundation insulation, structural steel, metal decking, slabs-on-grade, elevated concrete slabs, unit masonry, exterior and interior wall framing, roofing, insulation systems, sealants, doors, windows, rough carpentry, architectural woodwork, interior finishes, specialties, elevator, mechanical, plumbing, fire suppression, and electrical systems. 2. Site work: Stripping and stockpile of topsoil, excavation and trenching, dewatering, fill and compaction, and site improvements including landscaping, irrigation, paving, storm drainage and signage 3. Work identified as bid alternates, see Section 012300 Alternates.

Architect: CTA Architects Engineers, 13 North 23rd Street, Billings, MT (406)248-7455 (406)248-3779

**COLOR POSTERS UP TO 25FT!**

**SAME DAY SERVICE!**

**KALISPELL COPY CENTER**

**KALCOPY.COM**  
406-755-5888  
Fax: 755-5896

2303 Hwy 2 East  
Kalispell, MT 59901

**AML - ABANDONED MINE LAND DIVISION PROJECT 17.32-4 -  
CHEYENNE**

**CHEYENNE, WY**

**BIN:**

**BID DATE** 12/1/2015

**SCOPE:** This is a Task Order Contract for construction work at various in-state locations. At such time(s) as AML issues a written Task Order, the Contractor shall perform the specific job(s) described in the Task Order, which may include some or all of the following typical AML project reclamation activities: closure of shafts, adits, and subsidence features; injection grouting of underground voids; stabilization or removal and disposal of dilapidated mining-related structures; grading, stockpiling or removal of spoils, waste rock, gob, tailings and other mining or mineral processing byproducts and waste materials; construction of drainage structures; revegetation of reclaimed sites; fencing of reclaimed and/or hazardous sites; use of bat grates or cable nets for closure of mine openings; mine or subsidence abatement; mine fires, slack fires, and coal seam fires; disposal of unsuitable materials; construction of wooden shaft covers; revegetation, weed control, drilling and sampling to determine subsurface conditions, and ground water monitoring well construction.

**Issuing Office:** Department of Administration and Information, 700 West 21st Street, Cheyenne, WY 82002 (307)777-6708 (307)777-6708

**DEADWOOD WELCOME CENTER PROJECT**

**DEADWOOD, SD**

**BIN:**

**ADDENDA:** 1

**BID DATE** 12/2/2015

**PREBID:** 11-11 at 1PM at the City Hall.

**SCOPE:** The Work consists of the following: 1. The Work includes: New Visitor Center building and associated mechanical, electrical, utilities, sitework and landscaping. 2. Demolition of the existing trolley station building. 3. New Parking Lot, sidewalks and trolley turnaround. 4. New creek access walks, bank stabilization, retaining walls, pedestrian bridge and abutments. 5. Pedestrian and parking lot lighting.

**Architect:** Chamberlin Architects, 725 St. Joseph Street, Suite B1, Rapid City, SD 57701 (605)355-6804

**MINER'S FIELD AT COPPER MOUNTAIN SPORTS PARK  
LIGHTING SYSTEM**

**BUTTE, MT**

**BIN:**

**BID DATE** 12/2/2015 **PREBID:** MANDATORY 11-19-2015 1p.m. @ Copper Mountain Sports Park email jbryson@pioneer-technical.com and let him know you will be coming to the pre bid meeting

**SCOPE:** Work shall consist of, but is not necessarily limited to design, manufacture, and delivery of an eight-pole sports field lighting system freight-on-board (FOB) to Miner's Field located in Butte, Montana.

**Engineer:** Pioneer Technical Service, 63 1/2 W. Broadway, Butte, MT 59701 (406)782-5177 (406)782-5866

**Helena Copy Center**

**406-457-2679 • Fax 406-457-0226**

**1530 Cedar Street, Suite C • Helena, MT 59601**

**planex@helenacopycenter.com www.montanaplansexchange.com**

**HELENA PLANS EXCHANGE**

**SWEETWATER COUNTY SCHOOL DISTRICT NO. 1 - NEW  
FARSON-EDEN K-12 SCHOOL**

**ROCK SPRINGS, WY**

**BIN:**

**ADDENDA: 1**

**BID DATE** 12/3/2015

**PREBID: MANDATORY 11-24 at 2PM on site.**

**SCOPE:** Description: The project is the construction of a new 75,255sf K-12 School Facility, demolition of the existing facility, and site development which includes new football stadium and various other amenities. Work includes but is not limited to: Site clearing, earthwork, rammed aggregate piers, asphalt and concrete paving, irrigation systems, fencing, exterior plants, cast-in-place concrete, masonry, steel work, metal stairs and railings, plywood sheathing, casework, interior finishes, single-ply membrane roofing and accessories, fire stopping, wood and steel doors, aluminum storefront framing and doors, wood athletic flooring, painting, toilet partitions and accessories, flagpoles, signage, fire extinguishers and cabinets, folding panel partitions, gym equipment, communication and security systems, food service equipment and systems, theatrical equipment and systems, plumbing systems and fixtures, mechanical systems and fixtures, and electrical systems and fixtures.

**Issuing Office:** Wyoming School Facilities Department - Purchasing, (307)777-8671  
2300 Capital Ave, Cheyenne, WY 82001

**POLLEYS SQUARE BUILDING B BID PACKAGE 2**

**MISSOULA, MT**

**BIN:**

**BID DATE** 12/3/2015

**SCOPE:** Bid Package 2 – Bid date Thursday, December 3rd, 2015 at 4:00 pm  
Bid Package 2 work includes all landscaping and building construction that is not included in Bid Package 1.

All bids and proposals are to be submitted to the offices of the Construction Manager on the above dates by fax or email to:

Quality Construction Company  
Attention: Eric Reiber  
Fax: (406) 542-3639  
Email: EReiber@qualityconstruction.com

**General Contractor:** Quality Construction Company, 2800 South Reserve, (406)728-0080 (406)542-3639  
Missoula, MT 59806

**2303 Hwy 2 East Kalispell, MT 59901**

**KALCOPY.COM**  
**COLOR PLOTS AND POSTERS**

Yeah, We Do That Too!

**KALISPELL COPY CENTER**

The advertisement features a scenic photograph of a blue and silver passenger train curving along a track next to a clear blue river. The background is a lush, green, hilly landscape. The text is overlaid on the image in various colors and fonts, including red, green, and white.

**MONTANA HISTORICAL SOCIETY MODULAR IN DRAWER  
SHELVING SYSTEM**

**HELENA, MT**

**BIN:**

**BID DATE** 12/4/2015 **PREBID:** An optional Pre-Proposal Conference/Walk Through will be conducted at 225 North Roberts Street, Helena, MT by November 10, 2015 at 11:00am.

**SCOPE:** The STATE OF MONTANA, Montana Historical Society ("State") is seeking a contractor to provide and install a Heavy Duty Modular Drawer in Shelving for the storage of museum objects. The Montana Historical Society building is a four story building. The Shelving System will be installed on the basement level of the MHS building in the Museum storage area. The Museum storage area has a concrete floor, with load-bearing pillars, sprinkler pipes and heads, HVAC ducts and vents.

An optional Pre-Proposal Conference/Walk Through will be conducted at 225 North Roberts Street, Helena, MT by November 10, 2015 at 11:00am. Offerors are encouraged to use this opportunity to ask clarifying questions, obtain a better understanding of the project, and to notify the State of any ambiguities, inconsistencies, or errors discovered upon examination of this RFP. All responses to questions during the Pre-Proposal Conference will be oral and in no way binding on the State.

**Owner:** Montana Historical Society, Helena, MT 59601 (406)444-0110

**UPGRADE LIGHTING AT THE FISH CREEK CAMPGROUND  
AMPHITHEATER - GLACIER NP**

**GLACIER NATIONAL  
PARK, MT**

**BIN:**

**BID DATE** 12/7/2015

**SCOPE:** This project will upgrade the lighting components at the existing amphitheater area to improve accessibility, safety, and visitor experience while protecting night sky resources through appropriate lighting technology. The lighting system throughout the amphitheater area and in the projection booth will be upgraded to improve functionality, control, and performance. The contractor is responsible for providing fully operational lighting that meets all applicable building codes and standards.

**Issuing Office:** NPS, IMR - Northern Rockies MABO , PO Box 168, (406)888-7870 (307)344-2079  
Mammoth Supply Building #34, Yellowstone NP, WY  
82190

**DEFENSE ACCESS ROAD BY MILE STANFORD, JUDITH BASIN  
COUNTY, MONTANA**

**STANFORD, MT**

**BIN:**

**BID DATE** 12/9/2015

**SCOPE:** Road B-06 is located approximately 6 miles West of Stanford, MT on US 87; Road C-08 is located approximately 2 miles West of Stanford, MT on US 87 and South approximately 7 miles on Running Wolf Road; Road C-10 is located approximately 2 miles West of Stanford, MT on US 87.

**WORK:** This project consists of roadway reconditioning, aggregate surfacing, aggregate stabilization, grading, drainage, and other small items of work.

**Issuing Office:** U.S. Dept. of Transportation Federal Hwy, 610 East (360)619-7520 (360)619-7932  
Fifth Street, Vancouver, WA 98661



**WYDOT HIGHWAY PROJECTS**

**VARIOUS, WY**

**BIN:**

**BID DATE** 12/9/2015

**SCOPE:** 001 0251155 Cheyenne - Chugwater (Cheyenne North Section) Grading, draining, milling plant mix, bituminous pavement surfacing, plant mix wearing course, concrete slab replacement, reclaimed asphalt pavement widening, bridge rehabilitation and miscellaneous work on 7.56 miles on I-25 beginning at RM 16.64 between Cheyenne and Chugwater.

002 N471002 Casper Streets (US 20/26 Spur West) Grading, draining, milling plant mix, placing crushed base, bituminous pavement surfacing, plant mix wearing course, concrete pavement, bridge rehabilitation, removal and replacement of guardrail and miscellaneous work on 1.07 miles on the US 20/26 west spur beginning at RM 0.13 in the City of Casper.

003 N303043 Diversion Dam Jct . - Riverton (Wind River Section) Grading, draining, milling plant mix, placing crushed base and bituminous pavement surfacing, chip seal, bridge rehabilitation, fencing and miscellaneous work on 5.062 miles on US 26 beginning at RM 99.62 between Dubois and Riverton.

004 N852002 Cheyenne - Torrington (Berry Section) Grading, draining, milling plant mix, placing base and bituminous pavement surfacing, chip seal, reclaimed asphalt pavement, concrete headwall, fencing and miscellaneous work on 8.01 miles on US 85 beginning at RM 27.30 between Cheyenne and Torrington.

005 N341114 Casper - Shoshoni Grading, draining, milling plant mix and concrete, placing crushed base and bituminous pavement surfacing and miscellaneous work on 7.00 various miles on US 20/26 beginning at RM 14.00 between Casper and Shoshoni.

006 B163002 District 3 Contract Patching Grading, milling plant mix, bituminous pavement surfacing and miscellaneous work at various locations in Transportation District 3.

Issuing Office: Wyoming Department of Transportation , 5300 Bishop Blvd, Cheyenne, WY (307)777-4487

**SD DEPARTMENT OF TRANSPORTATION MAINTENANCE SHOP REMODEL AND ADDITION**

**FAULKTON, SD**

**BIN:**

**BID DATE** 12/10/2015

**PREBID:** 12-3 10:30 am Department of Transportation

**SCOPE:** labor and materials for Office and Maintenance Shop Remodel and Addition

**Owner:** Office of the State Engineer, 523 East Capital, Pierre, SD 57501

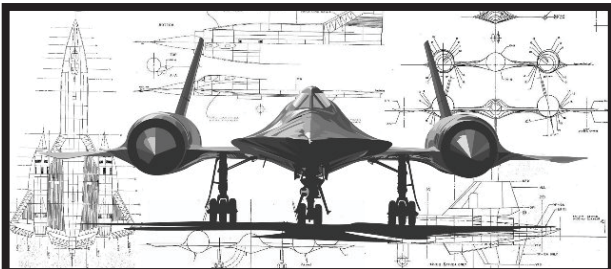

**LARGE FORMAT CONSTRUCTION DRAWINGS**

- 18"X24"
- 24"X36"
- 48"X60"
- 36"X48"



<b>KALISPELL COPY CENTER</b>	<b>755-5888</b>	<b>2303 HWY 2 EAST</b>
<b>HELENA COPY CENTER</b>	<b>457-2679</b>	<b>1530 CEDAR ST C</b>
<b>MISSOULA COPY CENTER</b>	<b>549-2679</b>	<b>2304 MCDONALD</b>

**WWW.MTCOPYCENTERS.COM**

**RELOCATION AND REHABILITATION OF HANAGER #5 -  
BISMARCK**

**BISMARCK, ND**

BIN:

BID DATE 1/4/2016

SCOPE: The City of Bismarck as owner of the Bismarck Airport announces the availability of historic Hangar 5 for relocating and preservation in compliance with the U.S Secretary of Interior's Standards for Treatment of Historic Properties.

Issuing Office: City of Bismarck - Bismarck Airport, 2301 University Drive Bldg 17, Suite 225B, Bismarck, ND 58504 (701)355-1808

**GARDINER GATEWAY PH 2 - ADVANCE NOTICE**

**GARDINER, MT**

BIN: Online

BID DATE 3/21/2016

SCOPE: Actual Bid Date TBD sometime late fall winter.

The attached preliminary plans are being furnished to aid prospective Offerors in identifying the location and type of work for this project. The project will be advertised during a period when viewing of the project may not be possible due to snow. Therefore, prospective Offerors are encouraged to view the project during fall as conditions permit. Although access to Gardiner Montana is open year-round, viewing of the site after November will be weather dependent; contact the Yellowstone National Parks 24-hour road information for current road conditions at 307-344-2117 or <http://www.nps.gov/yell/conditions.htm>. No Federal Highway Administration personnel will be available for show-me tours.

Technical Questions - All technical questions must be submitted by email [plans\\_spec@dot.gov](mailto:plans_spec@dot.gov) ([plans\\_spec@dot.gov](mailto:plans_spec@dot.gov)) or FAX 360-619-7932

General Questions - Contact our office at [wfl.contracts@dot.gov](mailto:wfl.contracts@dot.gov) or at 360-619-7520.

Issuing Office: Western Federal Lands Highway Division, 610 East Fifth Street, Vancouver, WA 98661 (360)619-7520 (360)619-7932



GENERAL CONTRACTORS

SWANKENTERPRISES.COM

DEWEY SWANK

P.O. BOX 10007  
750 WEST RESERVE DR.  
KALI SPELL, MT 59904-3007  
406/752-5411 - FAX 756-8765  
DEWEY@SWANKENTERPRISES.COM

**GRIZZLY SECURITY ALARMS, INC.**

Professional 24 Hour Monitoring

Fire • Burglary • Medical

CCTV • Intercoms

**SALES**

**406-755-4089**



Integrity, Reliability  
and Insured

Fax 406-257-2634 • [www.grizzlyalarms.com](http://www.grizzlyalarms.com)  
P.O. Box 7746 • Kalispell, MT 59904-0746

**COLOR POSTERS**

Yeah, We Do That Too!

**KALISPELL COPY CENTER**

[WWW.KALCOPY.COM](http://WWW.KALCOPY.COM)

406-755-5888 2303 Hwy 2 East Kalispell, MT 59901

**Sitka Builders**  
**Carson Brothers**  
**Fire Guys Leasing**  
**R & M Electric**  
**Janicki Const.**  
**SPC Asphalt**  
**Root Masonry**  
**White Rock Aggregate**  
**Mostly Montana Construction**  
**Road Products**  
**McCrumb Const. & Marine**



Thank you  
for enlisting!



Thank You, We Appreciate Your Business

## Flathead Septic Permits

10-22	Ralph O'Neil	314-3788	73 Longrider Ln.	Lakeside
10-23	David & Deanna Gray	253-0987	1725 Egan Slough Rd.	Kalispell
10-23	Victor J Gonzalez	253-5373	920 Potter Creek Rd.	Olney
10-26	John Powell	261-3698	1520 Karrow Ave.	Whitefish
10-26	Mark Beloit	471-5787	985 Blue Lake Ln.	Bigfork
10-26	Paul R. Walker	270-5609	101 River Estates Dr.	C Falls
10-28	Chris West	885-6520	1260 Quail Ridge Dr.	Kalispell
10-28	Jody Emerson	249-4527	837 Berne Rd.	C Falls
10-28	Pickering Family Homes	250-0839	1139 Moonbow Loop	Kalispell
10-29	<b>B.I.D. Inc. / Robert Wager</b>		<b>1114 Homesteaders Way</b>	<b>Marion</b>
10-30	<b>Ron Terry Const.</b>	<b>253-3083</b>	<b>42 Bluebird Dr.</b>	<b>Kalispell</b>
11-02	<b>Larry &amp; Jo Rowland</b>	<b>250-7249</b>	<b>225 Westridge Dr.</b>	<b>Somers</b>
11-02	<b>Shawn Krauss</b>	<b>249-5999</b>	<b>1467 HWY 82</b>	<b>Somers</b>
11-03	<b>FVCC</b>	<b>752-5205</b>	<b>216 Hutton Ranch Road</b>	<b>Kalispell</b>
11-04	<b>Lance Norman</b>	<b>314-1765</b>	<b>410 Meadow Ln.</b>	<b>Whitefish</b>

# Kalispell Permits

F15-042	10/12/2015	1005 TREELINE RD	Treeline Village, LLC	Montana Fire Sprinklers	Apartments	New	Work Description: Install Fire Sprinkler System	\$20,000.00
F15-048	10/12/2015	1035 TREELINE RD	Treeline Village, LLC	Montana Fire Sprinklers	Apartments	New	Work Description: Install Fire Sprinkler System	\$20,000.00
F15-050	10/12/2015	1045 TREELINE RD	Treeline Village, LLC	Montana Fire Sprinklers	Apartments	New	Work Description: Install Fire Sprinkler System	\$20,000.00
F15-052	10/12/2015	1055 TREELINE RD	Treeline Village, LLC	Montana Fire Sprinklers	Apartments	New	Work Description: Install Fire Sprinkler System	\$20,000.00
F15-056	10/12/2015	1075 TREELINE RD	Treeline Village, LLC	Montana Fire Sprinklers	Apartments	New	Work Description: Install Fire Sprinkler System	\$20,000.00
F15-054	10/12/2015	1065 TREELINE RD	Treeline Village, LLC	Montana Fire Sprinklers	Apartments	New	Work Description: Install Fire Sprinkler System	\$20,000.00
R15-140	10/13/2015	277 ROSEWOOD DR	Chris Barry	4J Builders	Single Family Residence	Addition	Work Description: Build 750 ft2 addition to attached SFR garage.	\$20,400.00
R15-125	10/13/2015	149 PARKRIDGE DR	Bridgeland Properties	Westcraft Homes	Single Family Residence	New	Work Description: Build 3 bedroom 2 bath SFR on crawl space with attached garage.	\$250,000.00
C15-142	10/14/2015	119 E IDAHO ST	Pensco Trust	Steadfast Enterprises	Commercial	Remodel	Work Description: Re-roof and replacement of windows in existing commercial building.	\$12,000.00
F15-058	10/14/2015	242 STILLWATER RD	Burlage Family Properties	Stellar Integration & Safety	Nursing Home	New		\$7,600.00
F15-039	10/14/2015	820 S MAIN ST	Flathead County	Stellar Integration & Safety	Offices	Addition	Work Description: Install Fire Alarm System	\$23,500.00
R15-072	10/16/2015	170 CAMP CROOK AVE	Matt Grindrod	Gary Grindrod	Single Family Residence	New	Work Description: Build 3 bedroom 2 bath SFR on conditioned crawl space with attached garage.	\$156,100.00
F15-057	10/16/2015	242 STILLWATER RD	Burlage Family Properties	Elite Fire Protection	Nursing Home	New	Work Description: Install a full 13R Fire Sprinkler System	\$24,000.00
R15-147	10/20/2015	213 NORTHLAND DR	Bridgeland Properties	Westcraft Homes	Single Family Residence	New	Work Description: Build 4 bedroom 3.5 bath SFR with attached garage.	\$270,000.00
F15-040	10/20/2015	255 SUMMIT RIDGE DR	Kalispell Assembly of God Church	Montana Fire Sprinklers	Church	Addition	Work Description: Install Fire Sprinkler system into addition	\$38,000.00
F15-044	10/20/2015	1015 TREELINE RD	Treeline Village, LLC	Montana Fire Sprinklers	Apartments	New	Work Description: Install Fire Sprinkler System - Common Areas	\$20,000.00
R15-150	10/21/2015	321 5TH AVE E	Levi Reynolds	Owner	Single Family Residence	Repair	Work Description: Foundation repair per stamped engineering.	\$15,000.00
R15-132	10/26/2015	1105 3RD AVE W	Hazel Stefanatz	Owner	Single Family Residence	Addition	Work Description: Build 210 ft2 bedroom addition to existing SFR	\$25,000.00
C15-150	10/28/2015	22 5TH AVE W	John & Elizabeth Peschel Trust	Edge Exterior Coatings	Offices	Repair	Work Description: Reseal old SPF Foam Roof w/Acrylic Coatings/install metal drip edge/some roof sheathing	\$11,830.00
R15-148	10/28/2015	383 MOUNTAIN VISTA WAY	BID, Inc.	BID, Inc.	Single Family Residence	New	Work Description: Build a 4 bedroom 4 bath SFR on daylight basement with attached garage and deck.	\$266,564.00
C15-147	10/29/2015	2385 HIGHWAY 93 N	Thunderbird Associates	Panterra Construction	Retail	Remodel	Work Description: Remodel of existing tenant space. No change to egress or restrooms.	\$63,424.00

# OneStop Vendor Information



Montana Department of  
**LABOR & INDUSTRY**  
Employment Relations Division

Governor Steve Bullock  
Commissioner Pam Bucy

Labor Standards Bureau  
Wage and Hour Unit

October 29, 2015

Dear Interested Party,

A public hearing on the proposed 2016 Montana prevailing wage rates for building construction services, heavy construction services, highway construction services, and nonconstruction services will be held on November 20, 2015 at 10:00 a.m. in the second floor conference room (conference rooms A and B), 1805 Prospect Avenue, Helena, Montana.

A copy of the public hearing notice is enclosed with this letter. The proposed rates can be found on the internet by going to: <http://erd.dli.mt.gov/labor-standards>. **If you would like to receive future prevailing wage survey materials via email, or if you no longer want to be on the "Interested Parties" list to receive notices of hearings and new rates, please call or e-mail me.**

Sincerely,

Michael Smith  
Statistician  
[Msmith3@mt.gov](mailto:Msmith3@mt.gov)  
406-444-1741  
406-444-7071 (Fax)

enc.

**BETA**



Online Plan Service – On The Go.

Quickly access the Online Planroom, review project information and documents ON THE GO!

OPS Mobile is available as a mobile application, compatible with all Mobile devices such as Android, iOS, blackberry, and tablet platforms.

Access OPS Mobile on your mobile device by going to <http://onlineplanservice.com/mobile/> OPS Mobile is an abridged version of the OPR. It includes:

- My Desk
- New Projects
- Bidding Projects
- Bid Results.

Filters for project name and location are also available.

All Project Documents, Addenda, Plans, Specs etc. can be viewed using our OPS Mobile Viewer. As this is a web-based viewer, no installation is necessary.



OPS Mobile loads to My Desk. Navigate to New Projects, Bidding Project, and Bid results using the bottom links.



Project Details include basic project information; addenda, project contacts, and bidders.



QuickEye Mobile Viewer quickly displays project Plans, Specs, and Addenda

An advertisement featuring two silhouettes of people, one in a red shirt on the left and one in a blue shirt on the right, holding a large black banner. The banner contains the text "ADVERTISE YOUR PRODUCTS OR SERVICES" in large, white, bold, sans-serif capital letters. Below the banner, the text "Contact Us Today For your advertising needs. ads@kalcopy.com or 755-5888" is displayed in a smaller, bold, sans-serif font.

**ADVERTISE YOUR  
PRODUCTS OR SERVICES**

**Contact Us Today  
For your advertising needs.  
ads@kalcopy.com or 755-5888**

# FEDERAL OPPORTUNITIES IN MONTANA

Opportunity	Agency•Office•Location	Type	Posted On
<p><a href="#"><u>Consolidated Computational Research Center</u></a> NIHOF2016085 Z -- Maintenance, repair, and alteration of real property</p>	<p>Department of Health and Human Services National Institutes of Health Office of Research Facilities/Office of Acquisitions</p>	<p>Sources Sought</p>	<p>Nov 05, 2015</p>
<p><a href="#"><u>CUSTER GALLATIN NATIONAL FOREST - Hyalite Lake Loop Trail</u></a> AG-0398-S-15-0024 Z -- Maintenance, repair, and alteration of real property</p>	<p>Department of Agriculture Forest Service R-1 East Side Acquisition Team: Beaverhead-Deerlodge; Custer Gallatin; Helena; Lewis &amp; Clark NFs; Dakota Prairie NG</p>	<p>Solicitation / Cancelled</p>	<p>Nov 05, 2015</p>
<p><a href="#"><u>REGIONAL SHOP JANITORIAL SERVICES</u></a> AG-03R6-S-16-0005 S -- Utilities and housekeeping services</p>	<p>Department of Agriculture Forest Service R-1 Western Montana Acquisition Zone (Lolo NF; Flathead NF; Bitterroot NF; Regional Office; Aerial Fire Depot)</p>	<p>Combined Synopsis/Solicitation (Modified)</p>	<p>Nov 05, 2015</p>
<p><a href="#"><u>C--LED Lighting Phase I</u></a> VA25916R0063 C -- Architect and engineering services</p>	<p>Department of Veterans Affairs VA Rocky Mountain Consolidated Contracting Center Department of Veterans Affairs</p>	<p>Presolicitation / Service-Disabled Veteran-Owned Small Business</p>	<p>Nov 05, 2015</p>
<p><a href="#"><u>Seeley Lake Janitorial Services</u></a> AG-03R6-S-16-0010 S -- Utilities and housekeeping services</p>	<p>Department of Agriculture Forest Service R-1 Western Montana Acquisition Zone (Lolo NF; Flathead NF; Bitterroot NF; Regional Office; Aerial Fire Depot)</p>	<p>Combined Synopsis/Solicitation / Total Small Business</p>	<p>Nov 05, 2015</p>
<p><a href="#"><u>Correct Critical Health and Life Safety Hazards, Many Glacier Hotel, Annex 2,</u></a> P16PS00052 Y -- Construction of structures and facilities</p>	<p>Department of the Interior National Park Service NPS - All Offices</p>	<p>Presolicitation</p>	<p>Nov 04, 2015</p>
<p><a href="#"><u>BEAVERHEAD-DEERLODGE NATIONAL FOREST - Whetstone Trail Rehabilitation and Construction</u></a> AG-0356-S-16-0001 Y -- Construction of structures and facilities</p>	<p>Department of Agriculture Forest Service R-1 East Side Acquisition Team: Beaverhead-Deerlodge; Custer Gallatin; Helena; Lewis &amp; Clark NFs; Dakota Prairie NG</p>	<p>Presolicitation / Total Small Business</p>	<p>Nov 04, 2015</p>
<p><a href="#"><u>X--Browning Telehealth Clinic</u></a> VA25916R0058 X -- Lease or rental of facilities</p>	<p>Department of Veterans Affairs VA Rocky Mountain Consolidated Contracting Center Department of Veterans Affairs</p>	<p>Sources Sought</p>	<p>Nov 03, 2015</p>
<p><a href="#"><u>Belzona 3121 NF2 MR7 Membrane</u></a> FA4626-16-Q-0001 80 -- Brushes, paints, sealers &amp; adhesives</p>	<p>Department of the Air Force Air Force Global Strike Command 341 CONS</p>	<p>Combined Synopsis/Solicitation / Total Small Business</p>	<p>Nov 03, 2015</p>

# FEDERAL OPPORTUNITIES IN MONTANA

Opportunity	Agency•Office•Location	Type	Posted On
<p><a href="#"><u>X--The Government is seeking clinical space in Anaconda, MT</u></a> VA25916R0057 X -- Lease or rental of facilities</p>	<p>Department of Veterans Affairs VA Rocky Mountain Consolidated Contracting Center Department of Veterans Affairs</p>	<p>Sources Sought</p>	<p>Nov 02, 2015</p>
<p><a href="#"><u>X--Kalispell Vet Center DMT04279-001</u></a> VA25915R0457 X -- Lease or rental of facilities</p>	<p>Department of Veterans Affairs VA Rocky Mountain Consolidated Contracting Center Department of Veterans Affairs</p>	<p>Sources Sought</p>	<p>Nov 02, 2015</p>
<p><a href="#"><u>Repair MAF Windows, Insulation, Siding</u></a> FA4626-16-R-0002 Z -- Maintenance, repair, and alteration of real property</p>	<p>Department of the Air Force Air Force Global Strike Command 341 CONS</p>	<p>Sources Sought</p>	<p>Nov 02, 2015</p>
<p><a href="#"><u>Point-to-Point Data Circuits at Billings Area Indian Health facilities and hospitals</u></a> BAIHS-OIM-16-001 70 -- General purpose information technology equipment</p>	<p>Department of Health and Human Services Indian Health Service Billings Area Office</p>	<p>Special Notice</p>	<p>Nov 02, 2015</p>
<p><a href="#"><u>Z--Cooling Equipment Replacement Ft. Harrison, Montana</u></a> VA25916R0016 Z -- Maintenance, repair, and alteration of real property</p>	<p>Department of Veterans Affairs VA Rocky Mountain Consolidated Contracting Center Department of Veterans Affairs</p>	<p>Solicitation (Modified) / Service-Disabled Veteran-Owned Small Business</p>	<p>Nov 02, 2015</p>
<p><a href="#"><u>Security Screening Services to include comprehensive screening of passengers and baggage at four (4) Montana West Airports</u></a> HSTS05-15-C-SPP090 S -- Utilities and housekeeping services</p>	<p>Department of Homeland Security Transportation Security Administration Headquarters TSA</p>	<p>Justification and Approval (J&amp;A)</p>	<p>Oct 30, 2015</p>
<p><a href="#"><u>Catering BPAs</u></a> FA4626-16-A-CATERING 73 -- Food preparation and serving equipment</p>	<p>Department of the Air Force Air Force Global Strike Command 341 CONS</p>	<p>Combined Synopsis/Solicitation (Modified)</p>	<p>Oct 29, 2015</p>
<p><a href="#"><u>FEI SERVICE SUPPORT AGREEMENT</u></a> NOI-RML-C-1761319 66 -- Instruments &amp; laboratory equipment</p>	<p>Department of Health and Human Services National Institutes of Health National Institute of Allergy &amp; Infectious Diseases/AMOB</p>	<p>Combined Synopsis/Solicitation</p>	<p>Oct 28, 2015</p>
<p><a href="#"><u>Dental Services</u></a> AG-82A7-S-15-0094 Q -- Medical services</p>	<p>Department of Agriculture Forest Service WO-AQM JC Support</p>	<p>Presolicitation (Modified)</p>	<p>Oct 28, 2015</p>
<p><a href="#"><u>Drop Spreader</u></a> NIHOF2015083 36 -- Special industry machinery</p>	<p>Department of Health and Human Services National Institutes of Health</p>	<p>Combined Synopsis/Solicitation / Total Small Business</p>	<p>Oct 26, 2015</p>



# FEDERAL OPPORTUNITIES IN MONTANA

Opportunity	Agency•Office•Location	Type	Posted On
<p><u><a href="#">X--Government is Seeking Office Space in Helena, MT</a></u> VA25915R0378 X -- Lease or rental of facilities</p>	<p>Department of Veterans Affairs VA Rocky Mountain Consolidated Contracting Center Department of Veterans Affairs</p>	Sources Sought	Oct 26, 2015
<p><u><a href="#">Residential Reentry Center (RRC) Services and Home Confinement Services Located Within Five Miles of the Butte, Montana City Limits in the County of Silver-Bow Montana</a></u> RFI-200-1309-WS G -- Social services</p>	<p>Department of Justice Bureau of Prisons Acquisitions Branch</p>	Sources Sought	Oct 23, 2015



**406-212-4342**  
**304 Jellison Road**

- Ready Mix Concrete •
- All Crushed Gravel •
- Washed Rocks & Sand •
- Pea Gravel •

**SERVING THE FLATHEAD VALLEY**  
**EASY CREDIT TERMS**

**COLOR POSTERS**

*Yeah, We Do That Too!*

**KALISPELL COPY CENTER**

**SAME DAY SERVICE!**

[WWW.KALCOPY.COM](http://WWW.KALCOPY.COM)

406-755-5888  
Fax: 755-5896

2303 Hwy 2 East  
Kalispell, MT 59901



# FAST COLOR COPIES!!

◇ **KALISPELL**  
◇ **HELENA**  
◇ **MISSOULA**

<b>KALISPELL COPY CENTER</b>	<b>755-5888</b>	<b>2303 HWY 2 EAST</b>
<b>HELENA COPY CENTER</b>	<b>457-2679</b>	<b>1530 CEDAR ST C</b>
<b>MISSOULA COPY CENTER</b>	<b>549-2679</b>	<b>2304 MCDONALD</b>

**WWW.MTCOPYCENTERS.COM**



# FEDERAL OPPORTUNITIES IN SOUTH DAKOTA

Opportunity	Agency•Office•Location	Type	Posted On
<p><a href="#"><u>Provide remake of glasses due to errors on orders</u></a> IHS1276871 Q -- Medical services</p>	<p>Department of Health and Human Services Indian Health Service Aberdeen Area Office</p>	<p>Special Notice / Cancelled</p>	<p>Nov 05, 2015</p>
<p><a href="#"><u>WRD - Delta Dust</u></a> AG-65T0-S-16-0003 68 -- Chemicals &amp; chemical products</p>	<p>Department of Agriculture Forest Service R-2 Nebraska National Forest</p>	<p>Solicitation (Modified)</p>	<p>Nov 05, 2015</p>
<p><a href="#"><u>DR-4237-OST Residential Housing Repair / Construction</u></a> HSFE08-16-R-0011 Z -- Maintenance, repair, and alteration of real property</p>	<p>Department of Homeland Security Federal Emergency Management Agency Region IX</p>	<p>Combined Synopsis/Solicitation (Modified)</p>	<p>Nov 03, 2015</p>
<p><a href="#"><u>J--568-16-1-9006-0003 Elevator Maintenance and Repair - BHHCS</u></a> VA26316R0030 J -- Maintenance, repair &amp; rebuilding of equipment</p>	<p>Department of Veterans Affairs VA Black Hills Health Care System Department of Veterans Affairs Black Hills Health Care System</p>	<p>Solicitation</p>	<p>Nov 03, 2015</p>
<p><a href="#"><u>Q--Sioux Falls Wheelchair Seating Clinic</u></a> VA26316N0074 Q -- Medical services</p>	<p>Department of Veterans Affairs Minneapolis VAMC Department of Veterans Affairs Medical Center</p>	<p>Sources Sought</p>	<p>Nov 02, 2015</p>
<p><a href="#"><u>Firm Fixed-Price, commercial item task order for endoscopic supplies</u></a> 65 -- Medical, dental &amp; veterinary equipment &amp; supplies</p>	<p>Department of Health and Human Services Indian Health Service Aberdeen Area Office</p>	<p>Justification and Approval (J&amp;A)</p>	<p>Nov 02, 2015</p>
<p><a href="#"><u>Non-Personal service purchase order for monthly technical support for the M-System in the P&amp;S Dept.</u></a> R -- Professional, administrative, and management support services</p>	<p>Department of Health and Human Services Indian Health Service Aberdeen Area Office</p>	<p>Justification and Approval (J&amp;A)</p>	<p>Nov 02, 2015</p>
<p><a href="#"><u>Non-Personal for full service PM on the System1E Steam Sterilizer</u></a> J -- Maintenance, repair &amp; rebuilding of equipment</p>	<p>Department of Health and Human Services Indian Health Service Aberdeen Area Office</p>	<p>Justification and Approval (J&amp;A)</p>	<p>Nov 02, 2015</p>
<p><a href="#"><u>SO Warehouse &amp; Trailer</u></a> AG-67T0-S-16-0001 Z -- Maintenance, repair, and alteration of real property</p>	<p>Department of Agriculture Forest Service R-2 Black Hills National Forest</p>	<p>Solicitation (Modified)</p>	<p>Nov 02, 2015</p>
<p><a href="#"><u>PEST CONTROL - LOWER BRULE, SD</u></a> IHS1276347 Z -- Maintenance, repair, and alteration of real property</p>	<p>Department of Health and Human Services Indian Health Service Aberdeen Area Office</p>	<p>Combined Synopsis/Solicitation (Modified)</p>	<p>Oct 30, 2015</p>
<p><a href="#"><u>G--Sioux Falls Homeless Emergency Housing</u></a> VA26316N0072 G -- Social services</p>	<p>Department of Veterans Affairs Minneapolis VAMC Department of Veterans Affairs Medical Center</p>	<p>Sources Sought</p>	<p>Oct 30, 2015</p>

# FEDERAL OPPORTUNITIES IN SOUTH DAKOTA

Opportunity	Agency•Office•Location	Type	Posted On
<a href="#">Snow Removal Services</a> WC-133W-16-RQ-0022 S -- Utilities and housekeeping services	Department of Commerce National Oceanic and Atmospheric Administration (NOAA) Eastern Region Acquisition Division-KC	Combined Synopsis/Solicitation / Total Small Business	Oct 30, 2015



**Rod Taylor**  
CONTRACTOR

406.756.0705  
1855 Trumble Creek Road  
Kalispell, MT 59901

BIBS • BLOWN-IN ATTICS • BATTS • FREE ESTIMATES



73 MORNING GLORY LANE  
KALISPELL, MT 59901  
OFFICE 406-257-4639  
FAX 406-257-6169

COMPLETE PROPERTY MAINTENANCE

**MICHELLE WEDDLE**

MICHELLE@ROCKYMTNSUPERVAC.COM

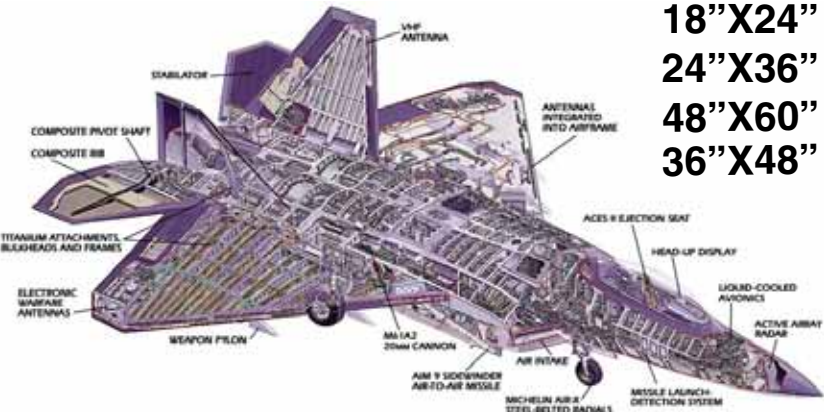

**18"X24"**  
**24"X36"**  
**48"X60"**  
**36"X48"**

**LARGE FORMAT DRAWINGS**

◆ **KALISPELL**  
◆ **HELENA**  
◆ **MISSOULA**

**KALISPELL COPY CENTER 755-5888 2303 HWY 2 EAST**  
**HELENA COPY CENTER 457-2679 1530 CEDAR ST C**  
**MISSOULA COPY CENTER 549-2679 2304 MCDONALD**

**WWW.MTCOPYCENTERS.COM**



756-WIRE

Edward S. Ek - President  
Commercial • Residential

(406) 756-9473  
Fax: (406) 756-9474  
P.O. Box 5428  
Kalispell, MT 59903

ed@756wire.com

**24 Hour Service**



2890 Hwy 2 East  
Kalispell, MT 59901



1-800-835-1116  
Cell: 406-253-6790  
Phone: 406-756-8033  
Fax: 406-756-8038

**BOB KRUSE**

# FEDERAL OPPORTUNITIES IN NORTH DAKOTA

Opportunity	Agency•Office•Location	Type	Posted On
<p><b><u>Williston 2 Substation Stage 03</u></b> DE-SOL-0009165 Y -- Construction of structures and facilities</p>	<p>Department of Energy Federal Locations Western Area Power Administration</p>	<p>Presolicitation / Total Small Business</p>	<p>Nov 05, 2015</p>
<p><b><u>56--Minot AFB Design-Drainage, Repaving, improvement</u></b> W9128F-15-B-0006 56 -- Construction &amp; building materials</p>	<p>Department of the Army U.S. Army Corps of Engineers USACE District, Omaha</p>	<p>Solicitation (Modified)</p>	<p>Nov 03, 2015</p>
<p><b><u>R--VAMC Fargo Language Translation &amp; Interpretation Services</u></b> VA26316Q0074 R -- Professional, administrative, and management support services</p>	<p>Department of Veterans Affairs VA Black Hills Health Care System Department of Veterans Affairs Black Hills Health Care System</p>	<p>Solicitation / Total Small Business</p>	<p>Oct 30, 2015</p>



**TOUGHROCK.**  
**FIREGUARD 45™**  
GYPSUM BOARD

**Georgia-Pacific**

**Increase YOUR Home's Fire Resistance by Building with UL Classified 45-Minute Fire Rated Wall Assemblies**

Introducing patent-pending ToughRock® Fireguard 45™ Gypsum Board from Georgia-Pacific Gypsum - the only available standard 1/2" interior wallboard to be enhanced with fire-resistance properties for a 45-minute UL classified fire rating.



**NORTHWEST DRYWALL & ROOFING** SUPPLY INC.

160 8th Ave WN • Kalispell, MT 59901  
406-752-2644 • www.nw-drywall.com



◆ **KALISPELL**  
◆ **HELENA**  
◆ **MISSOULA**

**KALISPELL COPY CENTER** 755-5888 2303 HWY 2 EAST  
**HELENA COPY CENTER** 457-2679 1530 CEDAR ST C  
**MISSOULA COPY CENTER** 549-2679 2304 MCDONALD

**WWW.MTCOPYCENTERS.COM**

**COLOR PLOTS AND POSTERS**



**MISSOULA COPY CENTER**

2304 McDonald Ave.  
406-549-2679 • Fax 549-2697  
Email: missoulacopy@bresnan.net

# FEDERAL OPPORTUNITIES IN IDAHO

Opportunity	Agency•Office•Location	Type	Posted On
<p><u><a href="#">Contractor Operated Civil Engineer Supply Store (COCESS)</a></u> FA4897-16-B-0001 R -- Professional, administrative, and management support services</p>	<p>Department of the Air Force Air Combat Command 366 CONS</p>	Sources Sought	Nov 05, 2015
<p><u><a href="#">Linen Services for Centennial Job Corps Center</a></u> AG-82A7-S-16-0003 S -- Utilities and housekeeping services</p>	<p>Department of Agriculture Forest Service WO-AQM JC Support</p>	Solicitation (Modified)	Nov 03, 2015
<p><u><a href="#">IPNF Bonners Ferry RD, BP Blue Grass Repairs</a></u> AG-02RC-S-15-0138 Z -- Maintenance, repair, and alteration of real property</p>	<p>Department of Agriculture Forest Service R-1 IMAT: Clearwater; Idaho Panhandle; Kootenai; and Nez Perce NF's</p>	Solicitation (Modified) / Total Small Business	Nov 02, 2015
<p><u><a href="#">Residential Reentry Center services in Boise, Idaho.</a></u> RFP-200-1233-WS G -- Social services</p>	<p>Department of Justice Bureau of Prisons Acquisitions Branch</p>	Award	Nov 02, 2015

***COLOR POSTERS UP TO 25FT!***

KALCOPY.COM

**KALISPELL COPY CENTER**

406-755-5888  
Fax: 755-5896

2303 Hwy 2 East  
Kalispell, MT 59901



## MISSOULA COPY CENTER

2304 McDonald Ave.

406-549-2679 • Fax 549-2697

Email: [missoulacopy@bresnan.net](mailto:missoulacopy@bresnan.net)

[www.montanaplansexchange.com](http://www.montanaplansexchange.com)

# FEDERAL OPPORTUNITIES IN WYOMING

Opportunity	Agency•Office•Location	Type	Posted On
<p><a href="#"><u>Installation Bridge Guardrails and Terminal End Sections</u></a> AG-8544-S-15-0011 Y -- Construction of structures and facilities</p>	<p>Department of Agriculture Forest Service R-2 Shoshone National Forest</p>	<p>Award</p>	<p>Nov 05, 2015</p>
<p><a href="#"><u>WRJCC ENERGY PAD ELECTRICAL &amp; LIGHTING RPOJECT</u></a> WRJCC-ENERGY-PAD-ELECTRICAL-LIGHTING 99 -- Miscellaneous</p>	<p>Department of Labor Employment Training Administration Wind River Job Corps Center</p>	<p>Combined Synopsis/Solicitation (Modified)</p>	<p>Nov 05, 2015</p>
<p><a href="#"><u>Y--MRI Building</u></a> VA25915R0379 Y -- Construction of structures and facilities</p>	<p>Department of Veterans Affairs VA Rocky Mountain Consolidated Contracting Center Department of Veterans Affairs</p>	<p>Solicitation (Modified) / Service-Disabled Veteran-Owned Small Business</p>	<p>Nov 05, 2015</p>
<p><a href="#"><u>Replace Flooring - Wapiti &amp; Crandall Ranger Stations</u></a> AG-8544-S-15-0009 Z -- Maintenance, repair, and alteration of real property</p>	<p>Department of Agriculture Forest Service R-2 Shoshone National Forest</p>	<p>Solicitation / Cancelled</p>	<p>Nov 04, 2015</p>
<p><a href="#"><u>Doble Analyzer Repair</u></a> DE-SOL-0009124 66 -- Instruments &amp; laboratory equipment</p>	<p>Department of Energy Federal Locations Western Area Power Administration</p>	<p>Special Notice</p>	<p>Nov 04, 2015</p>
<p><a href="#"><u>WY NPS GRTE 217(1), Deadmans Bar Road, Parking Area and Ramp Improvements</u></a> DTFH70-16-R-00001 Y -- Construction of structures and facilities</p>	<p>Department of Transportation Federal Highway Administration (FHWA) Western Federal Lands Highway Division</p>	<p>Presolicitation</p>	<p>Nov 04, 2015</p>
<p><a href="#"><u>WY FLAP 129(1), Sand Creek Road</u></a> DTFH6815B00011 Y -- Construction of structures and facilities</p>	<p>Department of Transportation Federal Highway Administration (FHWA)</p>	<p>Solicitation (Modified)</p>	<p>Nov 03, 2015</p>
<p><a href="#"><u>K--Resolicitation for Reconfiguring a 28' Yellowstone boat</u></a> P16PS00038 K -- Modification of equipment</p>	<p>Department of the Interior National Park Service NPS - All Offices</p>	<p>Combined Synopsis/Solicitation (Modified)</p>	<p>Nov 03, 2015</p>
<p><a href="#"><u>Scissor Dock Installation - 2</u></a> WRJCC-ScissorDockInstallation2 99 -- Miscellaneous</p>	<p>Department of Labor Employment Training Administration Wind River Job Corps Center</p>	<p>Combined Synopsis/Solicitation (Modified)</p>	<p>Nov 02, 2015</p>
<p><a href="#"><u>Z--Supplemental Electrical Service to C Building</u></a> VA25916R0046 Z -- Maintenance, repair, and alteration of real property</p>	<p>Department of Veterans Affairs VA Rocky Mountain Consolidated Contracting Center Department of Veterans Affairs</p>	<p>Presolicitation / Service-Disabled Veteran-Owned Small Business</p>	<p>Oct 30, 2015</p>
<p><a href="#"><u>Z--Energy Audit Corrections - Air Handling Units</u></a> VA25915R0565 Z -- Maintenance, repair, and alteration of real property</p>	<p>Department of Veterans Affairs VA Rocky Mountain Consolidated Contracting Center Department of Veterans Affairs</p>	<p>Solicitation (Modified) / Service-Disabled Veteran-Owned Small Business</p>	<p>Oct 30, 2015</p>



# CUSTOM ON-SITE GRINDING

We have the equipment & expertise to fulfill your needs

- 750 HP Self-Propelled Rotochopper Grinder
- 130 Cubic Yard Walking Floor Trailers
- Clearing & Grubbing of Right-of-Ways
- Sized to Meet Your Specifications
- Logs, Brush, C&D Waste
- Fire Mitigation
- Licensed, Insured, Bonded

## OTHER PRODUCTS

Timbers, Beams, Bridge Planks, Dunnage, Rough Lumber

\*Mulch, Compost, Bark, Sawdust, Bio Fuel



30 Lump Gulch Road  
Clancy MT 59634  
Phone 406-933-5794  
Fax 406-933-9143

[www.markslumber.us](http://www.markslumber.us)



# Whitefish Permits

## Permits Issued - October 2015

Date Issued	Building Permit No.	Last Name / Business	First Name	House #	Street Name	Unit or Lot #	Contractor	Project Valuation	Building Permit Fee	Building	Review	Planning	Fire
<b>COMMERCIAL / REMODEL</b>													
10/15/15	7958	Lion MT Post #276	VFW	20	Baker Ave		Travis Brousseau	\$900	\$67	\$22	\$24	\$11	\$10
10/26/15	7956	542 Central LLC		542	Central Ave		Knox on Wood	\$60,000	\$1,313	\$428	\$464	\$214	\$207
10/30/15	7954	DA Davison & Co		210	E 2nd St		Blue Core	\$64,000	\$1,365	\$445	\$482	\$223	\$215
10/15/15	7952	Delaware North	Best Western	6510	Hwy 93S		Fire Suppression Systems	\$78,364	\$1,309	\$508	\$301	\$254	\$246
10/19/15	7950	Grouse Mtn Lodge		2	Fairway Dr		Dick Anderson Construction	\$348,500	\$4,395	\$1,433	\$1,552	\$717	\$693
								\$551,764	\$8,449	\$2,836	\$2,823	\$1,419	\$1,371
<b>DUPLEX - TOWNHOUSE / NEW CONSTRUCTION</b>													
10/07/15	7923	Timberland Real Est. LLC		728	Edgewood Pl	3B (rear)	Seven Hills Const.	\$113,000	\$1,642	\$640	\$373	\$320	\$309
10/07/15	7922	Timberland Real Est. LLC		726	Edgewood Pl	3A (front)	Seven Hills Const.	\$187,000	\$2,281	\$889	\$518	\$444	\$430
10/29/15	7921	Sage Partners LLC		407	Colorado Avenue	1	Blackwell Enterprises	\$142,500	\$1,901	\$741	\$432	\$370	\$358
10/29/15	7920	Sage Partners LLC		401	Colorado Avenue	2	Blackwell Enterprises	\$142,500	\$1,901	\$741	\$432	\$370	\$358
								\$442,500	\$5,824	\$2,270	\$1,323	\$1,134	\$1,097
<b>SINGLE FAMILY / ADDITION</b>													
10/16/15	7932	Krzyszyniak	Mike & Becky	135	Dakota Ave		Blankenship Const.	\$120,000	\$1,704	\$664	\$387	\$332	\$321
10/29/15	7931	Shigo	John	725	Somers Ave		Bearcat Bldg	\$90,000	\$1,422	\$554	\$323	\$277	\$268
10/15/15	8617	Kristensen	Nora	403	Columbia Ave	23 & 24	C&G Construction	\$135,000	\$2,368	\$714	\$952	\$357	\$345
								\$345,000	\$5,494	\$1,932	\$1,662	\$966	\$934
<b>SINGLE FAMILY / NEW CONSTRUCTION</b>													
10/27/15	7972	Lisa & Al Stinson	FOUNDATION	434	Dakota Ave		Dick Anderson Construction	\$275,000	\$3,039	\$1,184	\$691	\$592	\$572
10/21/15	7962	Triple S Land Group	FOUNDATION	761	Salmon Run	13	SSD Development	\$20,000	\$494	\$193	\$112	\$96	\$93
10/26/15	7941	Beck	Jeff	740	Aspen Grove St	18	Jeff Beck/Haskill Millworks	\$230,000	\$2,652	\$1,033	\$603	\$517	\$499
10/22/15	7935	Campbell	Brett	119	Brimstone Dr	2	North Valley Const.	\$285,000	\$3,127	\$1,218	\$711	\$609	\$589
								\$810,000	\$9,312	\$3,628	\$2,117	\$1,814	\$1,753
<b>SINGLE FAMILY / REMODELS</b>													
10/19/15	7961	Pearce	John	824	E 2nd St		owner	\$200	\$36	\$14	\$8	\$7	\$7
10/23/15	7960	Clark	Adam & Aubrey	515	W 3rd		owner	\$500	\$36	\$14	\$8	\$7	\$7
10/27/15	7959	McGowan	Greg	2059	Silverberry		Canyon Construction	\$55,000	\$1,046	\$407	\$238	\$204	\$197
10/15/15	7953	Harkness	Sam & Emily	1675	E 2nd St		Seven Hills Const.	\$5,000	\$171	\$67	\$39	\$33	\$32
10/07/15	7944	Schultz	Rick & Margarite	303 B	Dakota Ave		Mindful Designs	\$2,000	\$107	\$42	\$24	\$21	\$20
10/06/15	7940	Rottger	John	352	Sawtooth Dr		Tony Mauro	\$3,000	\$128	\$50	\$29	\$25	\$24
10/02/15	7929	Hannigan	Ed, Jr.	6	Swift Creek Ln		Ed Hannigan, Jr	\$1,500	\$84	\$33	\$19	\$16	\$16
								\$67,200	\$1,608	\$627	\$365	\$313	\$303

The Montana Contractors' Association Political Action Committee is one of Montana's largest and most respected Political Action Committees. Since 1994, the Contractors' PAC has given more than \$50,000 to help elect candidates of both parties who support contractors' issues. All contributions are reported to the Commissioner of Political Practices in accordance with Montana law.



By law, the Contractors' PAC cannot accept corporate donations. There is no limit on personal contributions to the Contractors' PAC. The Contractors' PAC is not a federally registered PAC and does not make contributions to candidates for federal office.

AGC's Build America PAC makes contributions on behalf of the Construction industry for federal races. *"Supporting the PAC is one of the most important things we can do to protect our interests as contractors."*

## Apprentice Level

A person contributing a minimum of \$300 cumulatively to the PAC in the calendar year is an "apprentice" member of the Club. He/she is acknowledged in the newsletter, receives a fine MCA logo shirt, and a lapel pin. Cumulatively means someone who contributes that amount of money during the course of the years through raffle tickets, cash contribution, auctions, etc.

## Journeyman Level

A person contributing \$1,000 in the calendar year is a "journeyman" member of the Club. He/ she is acknowledged in the newsletter, receives a lapel pin, a fine MCA logo shirt, and is invited to attend an exclusive reception during the annual convention for "PAC Builders."

## Master Level

A person contributing \$2,500 or more in the calendar year is a "Master" member of the Club. He or she receives all of the benefits listed for Journeyman members, and is presented with a plaque during the annual convention. Plaques will be updated for each year the individual qualifies.

### MONTANA PUBLIC WORKS STANDARD SPECIFICATION BOOK

...providing you with information that can help win bids

Contact the Montana Contractors' Association  
to order, or download the order form at  
[www.mtagc.org/docs/mpw-order-form.pdf](http://www.mtagc.org/docs/mpw-order-form.pdf)

Montana Contractors' Association  
(406) 442-4162 · 1717 11th Ave.  
Helena, MT 59601



### PROTECT YOUR RIGHTS AND YOUR BUSINESS

"Notice of Right to Claim a Lien"

20 Forms per Package

\$8.00 MCA Members · \$10.00 Non-Members

Three-part carbonless forms: for the Contract Owner,  
Clerk & Recorder, and your files

To order, contact:  
Montana Contractors' Association  
(406) 442-4162 · Fax: (406) 449-3199  
1717 11th Ave. · Helena, MT 59601





# LC STAFFING

Great People. Perfect Fit.

- ✓ Flexible Staffing Solutions
- ✓ Smart Payroll Options
- ✓ Complete Candidate Screening
- ✓ HR/Risk Consulting
- ✓ General Labor & Skilled Labor workers now available!
- ✓ Cost Effective Risk Control
- ✓ 25 years serving the Flathead

Let us help you **BUILD** your business!

702 East Idaho Street **752-0191** [www.lcstaffing.com](http://www.lcstaffing.com)

Contact us today!

# C I B

## Contractors Information Bureau



**“Where Construction Meets Commerce”**

**“ THE ALL CONSTRUCTION INDUSTRY AGENCY ”**

Individuals	Consumers	Contractor/ Trades	Professionals	Government	CIB Agency
					
Visibility	Professional Source	Reference Voice	Resource	Liabson	Corporate Responsibility

[www.CIBMONTANA.com](http://www.CIBMONTANA.com) and (406) 266-8031



Contact Us @ 406-755-5888 or [copies@kalcop.com](mailto:copies@kalcop.com)

**Call Now  
For  
Special Placement  
Options**